

Valve testing system VPS 508 for multiple actuators

8.13

DUNGS®
Combustion Controls

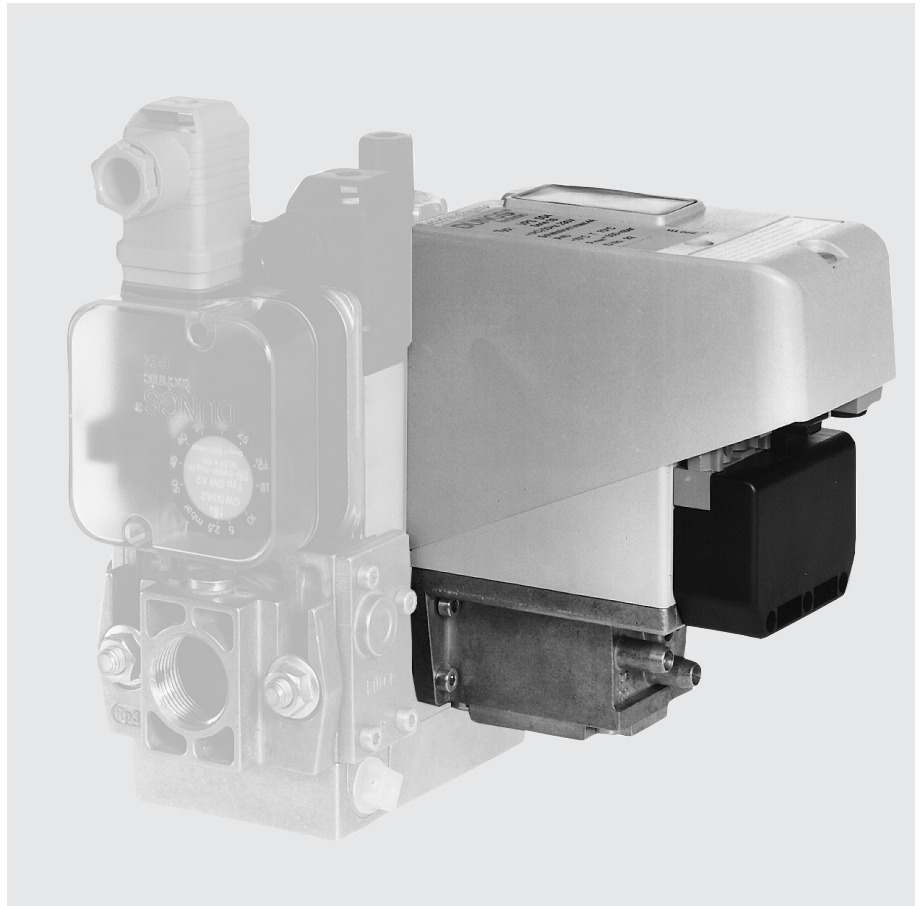

Technical description

The VPS 508 is the valve proving system for DUNGS multiple actuators. The valve proving system complies with EN 1643:

- Equipment operates independent of residual pressure in the range of the permissible operating range.
- Test volume ≤ 8 l
- Setting work not necessary on site
- Short test period: min. 10 s, max. 36 s
- Tightness or leaks are displayed by an LED
- External fault display possible for series 04 and S05
- Suitable for TRD systems
- Electrical connection possible by plug connection S03. No rewiring is required for contact allocation as per DIN 4791.
- S04 and S05: electrical connection at screw terminals via PG 13.5 cable entry

Application

Valve proving system for DUNGS single valves, DMV double solenoid valve and GasMultiBloc MB.

The VPS 508 can also be used for monitoring the DUNGS solenoid valves up to DN 100, with and without bypass connection.

24 VDC design for gas motors.

Suitable for gases of gas families 1, 2, 3 and other neutral gaseous media.

Approvals

EC type test approval as per EC Gas Appliance Directive:

VPS 508... CE-0085 AP 0168

EC type test approval as per EC Pressure Equipment Directive:

VPS 508... CE0036

Approvals in other important gas consuming countries.

VPS 508

Valve proving system for automatic shutoff valves as per EN 161, Class A and Class B

The VPS 508 may be used with any other valve whose tightness in counter-flow direction excludes by construction a leakage in flow direction.**The VPS 508 is suitable for all DUNGS valves according to EN 161 Classes A and B.****Specifications**

Operating pressure	max. 500 mbar (50 kPa)		
Test volume	≥ 1.5 l ≤ 8.0 l		
Pressure increase by motor pump	≈ 20 mbar		
Nominal voltage, Frequency	refer to type overview page 11		
Rating requirement	During pumping time approx. 60 VA, in operation 17 VA		
Prefuse (provided by customer)	10 A quick-acting or 6.3 A slow-acting fuse		
Fuse installed in housing cover, replaceable	Microfuse 6.3 slow-blow L 250 V; IEC-127-2/III (DIN 41 662)		
Switching current	Operating output	VPS 508 S03, S04, S05:	max. 4 A
	Refer to motor startup current!		
	Interference output	VPS 508 S04, S05:	max. 1 A
Degree of protection	VPS 508 S04, S05:	IP 54	
Ambient temperature	50 Hz 230 VAC -15 °C to +70 °C others: -15 °C to +60 °C		
Release time	Approx. 10 - 36 s, depending on test volume and input pressure		
Sensitivity limit	max. 50 l/h At inlet pressures of < 50 mbar, limit pressure rates well below 50 l of air per hour occur due to the mode of operation. This allows for applications involving low inlet pressures.		
Switch-on duration of control	100 % ED		
Max. number of test cycles	10/h. Wait for at least 2 minutes after carrying out more than 3 consecutive test cycles.		
Installation position	vertical, horizontal, not upside down		
Media	Gas families 1, 2, 3, sewage gas, landfill gas and biogas (dry, H ₂ S < 0.1 % by volume) and other gaseous media Not for gases having a butane content of > 60 %		

VPS 508 sectional diagram

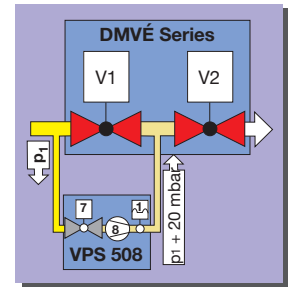
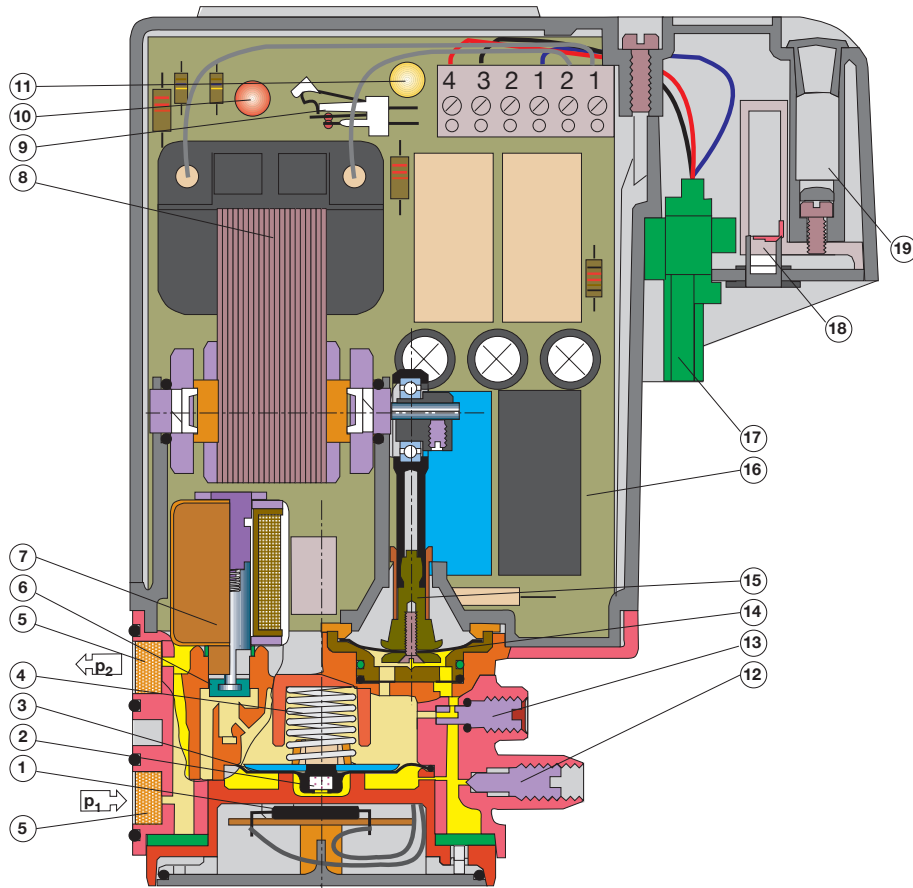

- | | | | | | |
|---|----------------------------|----|---------------------|----|-------------------|
| 1 | Hall switch | 7 | Solenoid valve coil | 13 | Volume restrictor |
| 2 | Solenoid | 8 | Pressure pump | 14 | Pump diaphragm |
| 3 | Pressure switch diaphragms | 9 | Unlock switch | 15 | Pump linkage |
| 4 | Compression spring | 10 | Fault lamp | 16 | PCB |
| 5 | Filter | 11 | Operating lamp | 17 | Plug connection |
| 6 | Solenoid valve anchor | 12 | Test nipple | 18 | Equipment fuse |
| | | | | 19 | Spare fuse |

Functional description

The VPS 508 operates depending on pressure build-up.

The program module starts to function when heat is requested.

Test is performed depending on the burner functional procedure:

Check **prior to** burner start or

Check **during** pre-purge period or

Check **after** burner shut-down

Function principle

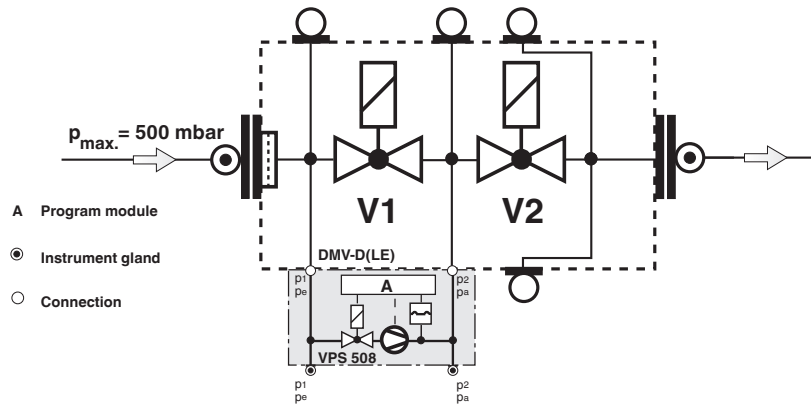

Release period t_F

Period which a VPS requires to perform a complete operation procedure. The release period of the VPS 508 depends on **test volume and input pressure**:

t_F max. ≈ 36 s

Test period t_{test}

Pumping time of motor pump.

Test volume V_{Test}

Volume between V1 output-side and V2 input-side and the intermediate tube pieces.

$$V_{test\ min. / VPS\ 508} = 1,5\ l$$

$$V_{test\ max. / VPS\ 508} = 8\ l$$

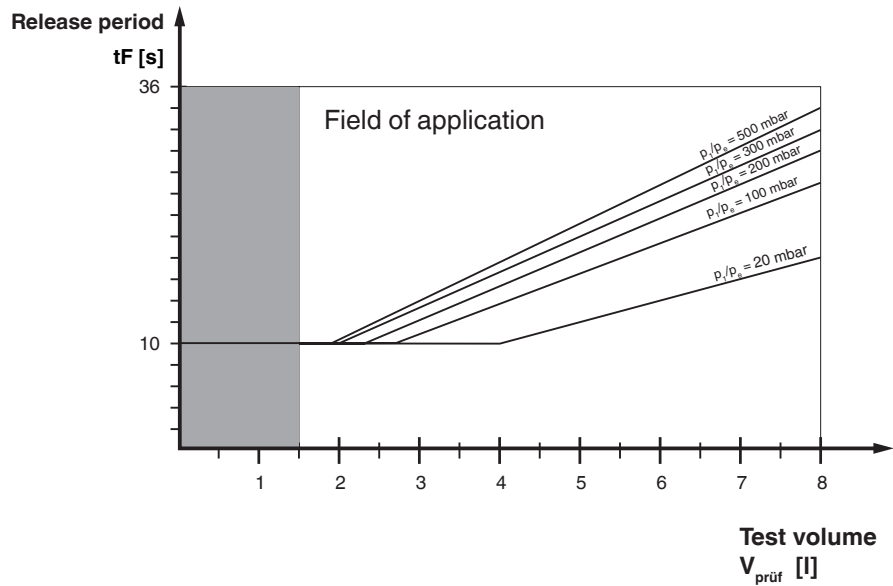

Program sequence

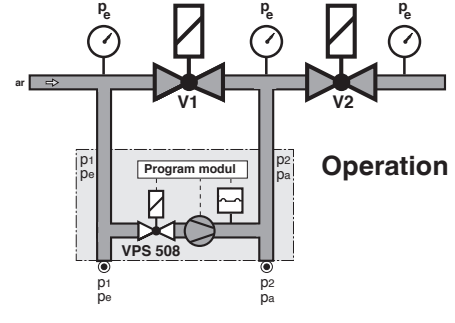
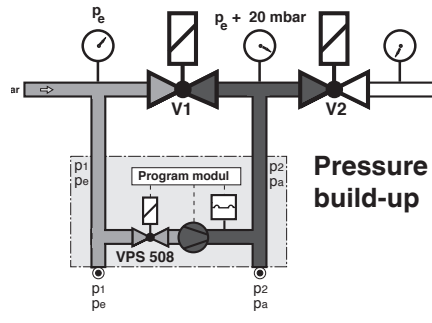
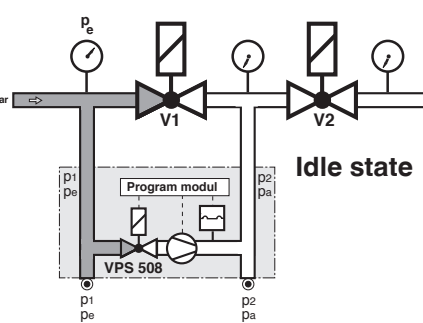

Idle state: Valves 1 and 2 are closed.

Pressure build-up: The internal motor pump increases the gas pressure in the test section by approx. 20 mbar compared to the input-side pressure applied to valve V1.

During the test period, the installed differential pressure switch monitors the test section for leakage. If the test pressure is attained, the motor pump is switched off (end of test period). The release time (10-36 s) depends on the

test volume (max. 8.0 l) and input pressure (max. 500 mbar). If the test section is tight, the contact is released to the automatic burner control after max. 36 s - the yellow signal lamp lights up.

If the test section is leaky or if the pressure increase by +20 mbar is not attained during the test period (max. 36 s), the VPS 508 switches to fault. The red signal lamp lights as long as the contact release by the regulator or thermostat is present (heat requirement).

If there is a short power failure during the test or burner operation, the test is started again automatically.

If the pumping time < approx. 10s, the pressure difference between the testing system and the inlet pressure is balanced after pumping is finished.

Operation: The internal valve of the VPS 508 is closed.

Program flowchart

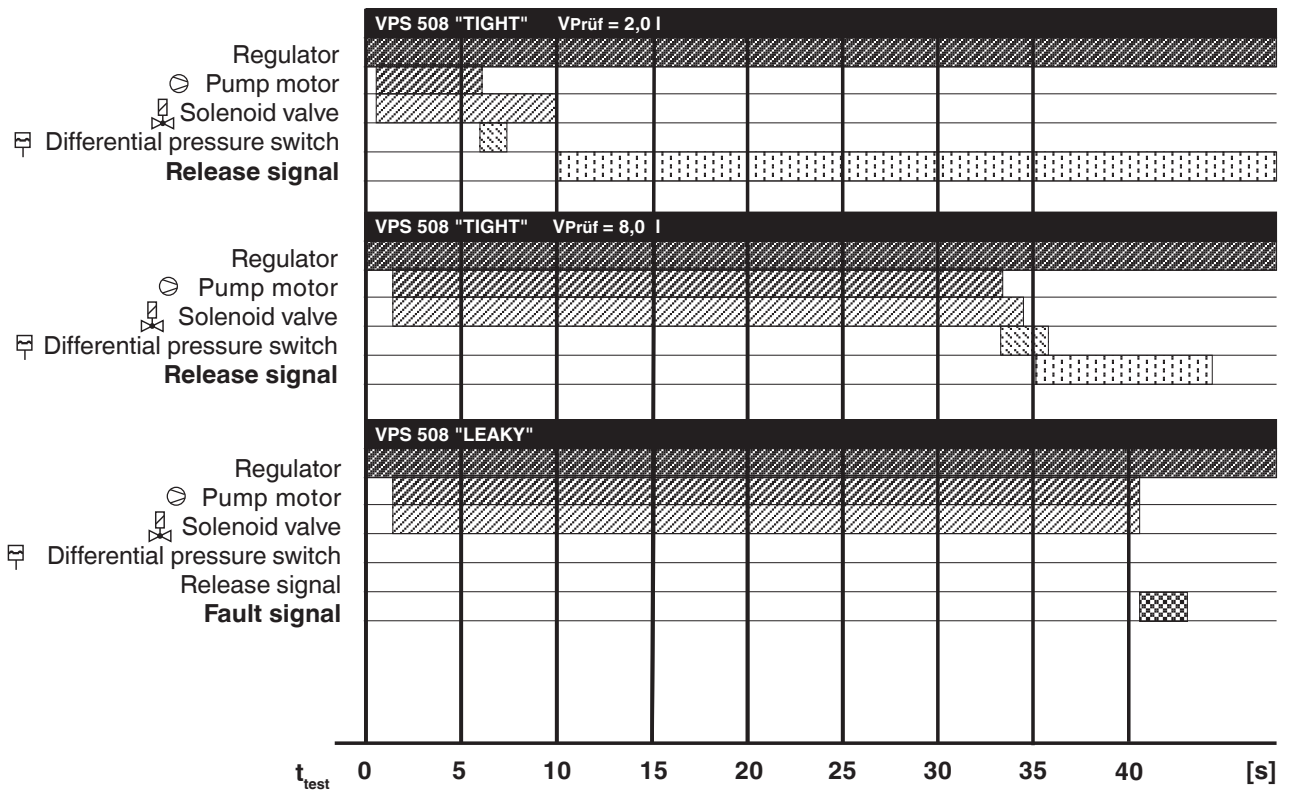

Electrical connection

VPS 508 S03

The VPS 508 S03 is connected in series between the temperature regulator and the control box via a 7-pin plug connector.

The pin assignment of the connector between burner and boiler is specified in DIN 4791. For contact assignment, refer to wiring diagram. If the heat generator is wired to DIN 4791, no boiler or burner rewiring is required for electrical connection.

Connect the burner connector to the floating connector of the VPS 508 S03.

Connect the VPS 508 S03 connector to the floating connector on the heat generator.

If there is a fault signal at S3 (burner fault), the regulator chain is bridged via an additional relay in VPS 508 S03 on the burner side. At the same time, the operating voltage of VPS 508 S03 is interrupted. After eliminating the burner fault, the valve testing system can be started again.



Only connect the incoming fault signal from the igniter of the burner control to port S3. If this is not observed, damage or injury may result. Therefore, please keep to the instructions.

- F1 Fuse
- F2 Sensor or limiter
- F3 Regulator
- H1 Fault signal
- H2 Operation signal
- P1 Operating hours meter stage 1
- S1 Switch
- X1B Connector, female
- X1S Connector, male

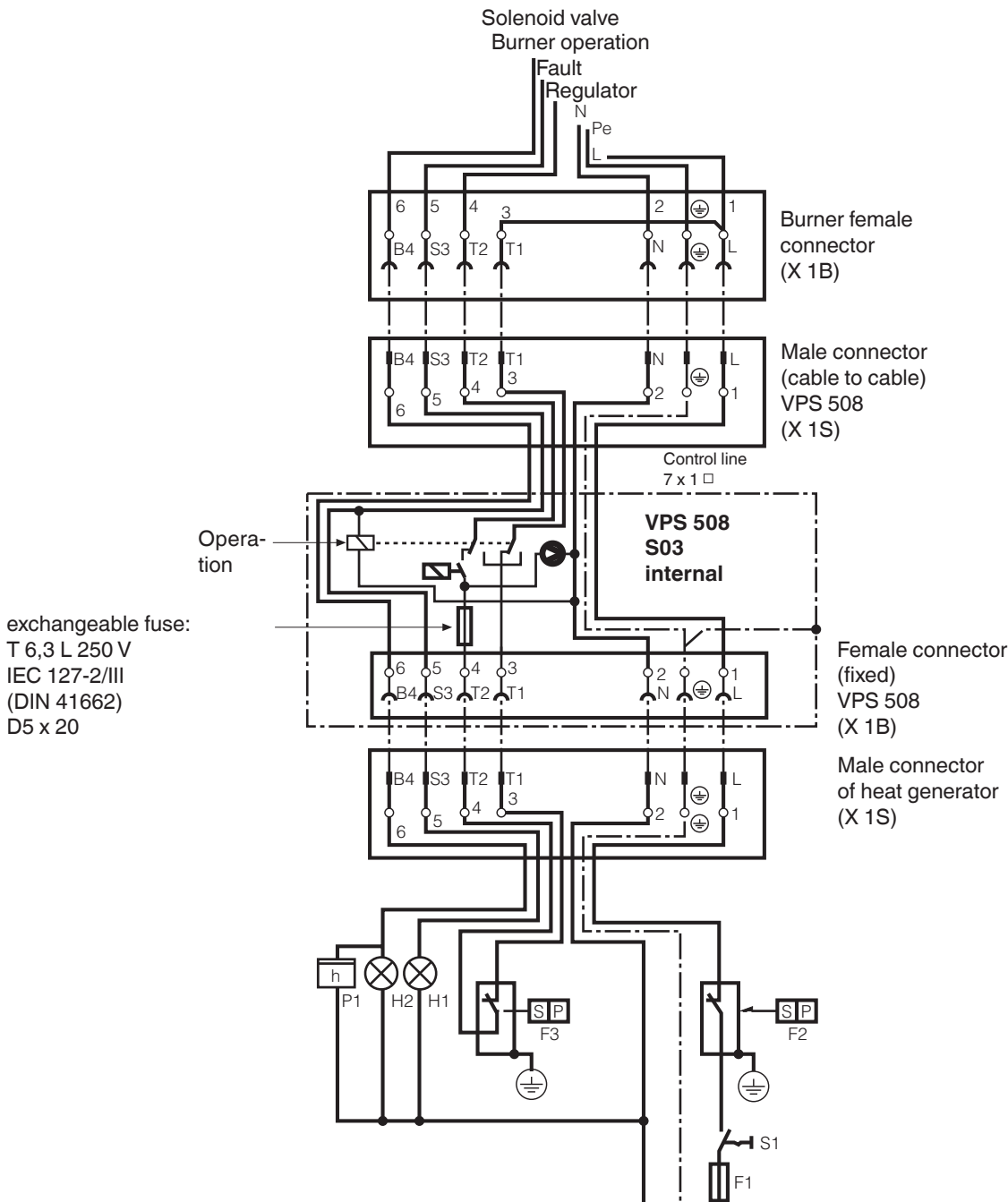

Electrical connection

VPS 508 S04

PG 13.5 cable duct and connection to screw terminals below cover in housing (see Dimensions VPS 508 S04, S05).



Floating control room signal may only be used for signalling, never for burner release.

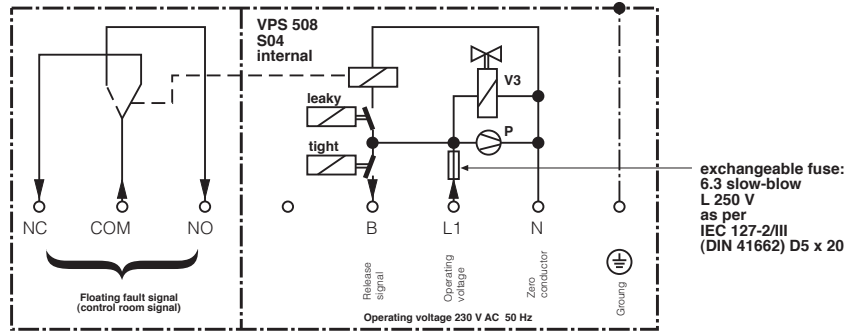

Electrical connection

VPS 508 S05

PG 13.5 cable duct and connection to screw terminals below cover in housing (see Dimensions VPS 508 S04, S06).



Operating voltage range 20 V - 30 V DC. Refer to motor startup current!

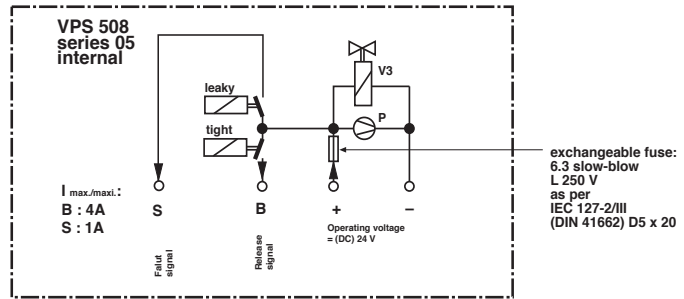

Test volume of DUNGS multiple actuators DMV-..., MBC-...

Type	Rp/DN	Test volume [l]	Type	Rp/DN	Test volume [l]
DMV-D(LE) 5080/11	DN 80	1,47 l	MBC 1900	DN 65	1,47 l
DMV-D(LE) 5100/11	DN 100	2,28 l	MBC 3100	DN 80	2,28 l
DMV-D(LE) 5125/11	DN 125	3,56 l	MBC 5000	DN 100	3,55 l
DMV-D(LE) 5065/12	DN 65	1,47 l	MBC 7000	DN 125	6,00 l
DMV-D(LE) 5080/12	DN 80	2,28 l			
DMV-D(LE) 5100/12	DN 100	3,55 l			
DMV-D(LE) 5125/12	DN 125	6,00 l			

Use of VPS 508 at DUNGS single valves.

Determining the test volume.

When mounting the VPS 508 on single valves DN 40-DN 100, the adapter set is required, **Ordering No. 222 740**.

Determining the test volume V_{test}

1. Determine the output volume of V1 (refer to table).
2. Determine the input volume of V2 (refer to table).
3. Determine the volume of the intermediate pipe part 3 (refer to table).

$$4. V_{\text{test}} = \text{Volumen}_{\text{valve 1}} + \text{Volumen}_{\text{intermediate pipe part}} + \text{Volumen}_{\text{valve 2}}$$

⚠ The max. test volume of 8 l must not be exceeded.

$$V_{\text{Test}} = \text{Valve volume V1 outlet+ V2 inlet} + \text{Volume of pipeline}$$

Demetering test volume V_{Test}

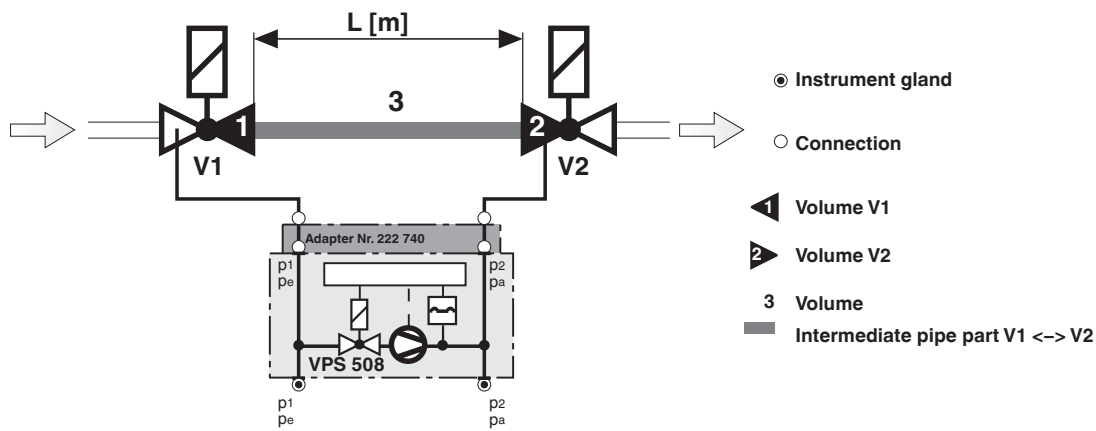

Rp / DN	Valve - Volume [l]		Test volume [l] = Volume V1 _{outlet} + V2 _{inlet} + Pipeline length							
	V1 _{outlet}	+ V2 _{inlet}	0,5 m		1,0 m		1,5 m		2,0 m	
	Rp	DN	Rp	DN	Rp	DN	Rp	DN	Rp	DN
Rp 3/8	0,01 l		0,06 l		0,11 l		0,16 l		0,21 l	
Rp 1/2	0,07 l		0,17 l		0,27 l		0,37 l		0,47 l	
Rp 3/4 (DN 20)	0,12 l		0,27 l		0,42 l		0,57 l		0,72 l	
Rp 1 (DN 25)	0,20 l		0,45 l		0,70 l		0,95 l		1,20 l	
Rp 1 1/2 / DN 40	0,50 l	0,70 l	1,10 l	1,35 l	1,70 l	2,00 l	2,20 l	2,65 l	2,80 l	3,30 l
Rp 2 / DN 50	0,90 l	1,20 l	1,90 l	2,20 l	2,90 l	3,20 l	3,90 l	4,20 l	4,90 l	5,50 l
DN 65		2,0 l		3,7 l		5,30 l		7,00 l		8,60 l
DN 80		3,8 l		6,3 l		8,80 l		11,30 l		13,80 l
DN 100		6,5 l		10,5 l		14,40 l		18,40 l		22,3 l
DN 125		12,0 l		18,2 l		24,3 l		30,50 l		36,6 l
DN 150		17,5 l		26,5 l		35,2 l		44,10 l		52,9 l
DN 200		46,0 l		61,7 l		77,4 l		93,10 l		108,9 l

—	VPS 504	$0,1 \text{ l} \leq V_{\text{prüf}} \leq 4,0 \text{ l}$
- - - -	VPS 508	$1,5 \text{ l} \leq V_{\text{prüf}} \leq 8,0 \text{ l}$
- - - - -	VDK	$0,4 \text{ l} \leq V_{\text{prüf}} \leq 20,0 \text{ l}$
.....	DSLK	$1,5 \text{ l} \leq V_{\text{prüf}}$

1 l = 1 dm³ = 10⁻³ m³

Startup

1. Check test section for leaks after assembly.
2. Start test by using temperature regulator and/or restart or by pressing the reset button of VPS 508.

3. If the test section is tight

Depending on the length of the test section and the residual pressure applied, the pumping time is between 3 s and 36 s.

The release for the automatic burner control is then given after approx. 10 s at the earliest (at small test volumes and small input pressures) and after approx. 36 s at the latest (at large test volumes and large input pressures) - the yellow signal lamp lights up.

If the test section is leaky

The test pressure is not attained.

The motor pump switches off, the red fault lamp lights up. Switch-through to the automatic burner control does not take place.

Functional check

By opening a screw plug in test nipple p_2 (p_a) during test period (pumping time), leakage can be simulated and a function check can take place.

Setting

The VPS 508 must **not** be adjusted on site.

Assembly

Directly flange the VPS 508 laterally to the DUNGS multiple actuators (mounting is possible on left-hand or right-hand side) using two 10.5 x 2.25 O rings and four M4 x 20 self-tapping screws.

 **If an exhaust gas valve is installed in the boiler, it must be open at the beginning of the test.**

 **In order to prevent functional and leakage problems, we recommend the use of solenoid valves as per EN 161 Class A and Class B.**

 **Insufficiently shielded frequency converters could cause faults in the VPS due to network disturbances. Make provisions for sufficient electrical shielding.**

**Dimensions [mm]
VPS 508 S03**

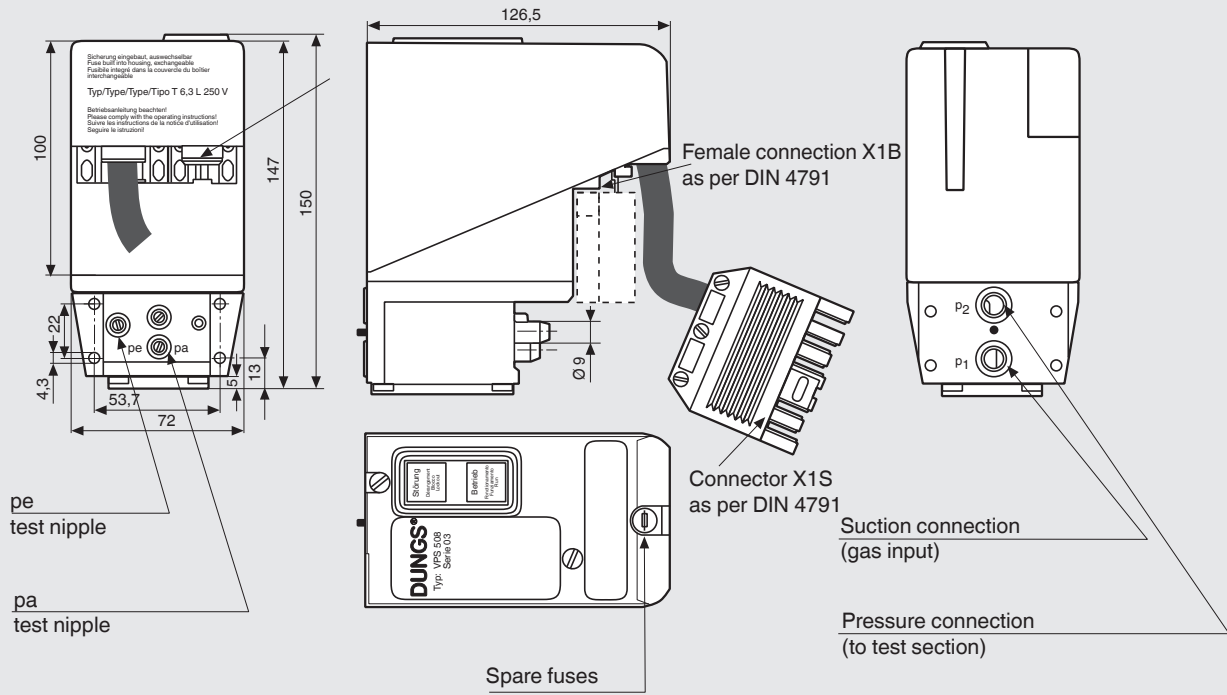

**Dimensions [mm]
VPS 508 S04, S05**

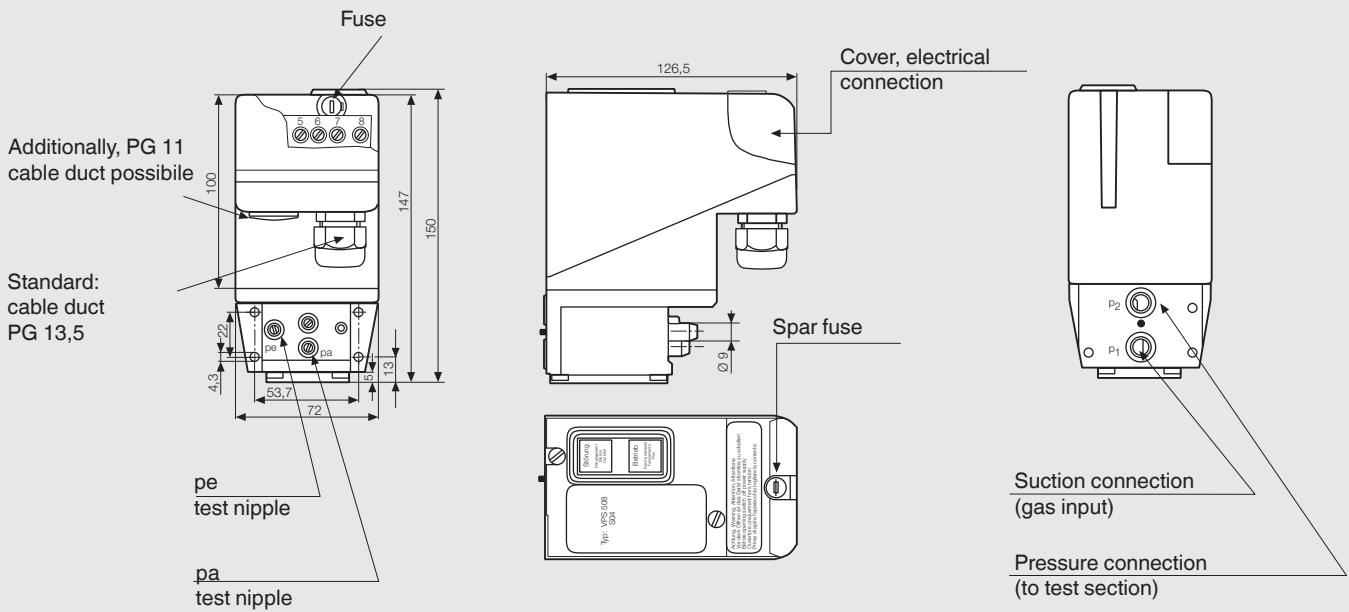

VPS 508 type overview / accessories / order data

Version VPS 508 Series ...	
Nominal voltage, Frequency	20-30 VDC
VPS 508 S05 (Gasmotors)	251 008
Accessories/spare parts	
Adapter kit VPS 504 for solenoid valves	222 740
Adapter kit VPS / VDK for solenoid valves	223 470
Mounting kit (4 x M4 x 20, 2 x O-Ring, 2 x filter insert)	221 503
Appliance fuse link (5 pieces)	231 780
Spare parts set VPS filter	243 801

**Valve testing system VPS 508
for multiple actuators**



We reserve the right to make any changes in the interest of technical progress.

Head Offices and Factory
Karl Dungs GmbH & Co. KG
Karl-Dungs-Platz1
D-73660 Urbach, Germany
Telephone +49 7181-804-0
Fax +49 7181-804-166

Postal address
Karl Dungs GmbH & Co. KG
Postfach 12 29
D-73602 Schorndorf, Germany
e-mail info@dungs.com
Internet www.dungs.com