

Trust > Knowledge > Loyalty



# Vertical Multistage In-line Centrifugal Pumps *XM/XMI/XMN Series*



*“Flow with one heart,  
Your Pumping Solutions!”*



#### **FLOTEQ SINGAPORE PTE LTD**

5 Yishun Industrial Street 1,  
#02-03, Northspring Bizhub,  
Singapore 768161  
Tel : (65) 6570 0820

#### **Floteq Pumps (Wuxi) Co.,Ltd**

2900 Jiaoyang Road, Anzhen, Xishan District,  
Wuxi, Jiangsu, P.R.China  
Post code: 214000  
Tel : (86) 510 88261830

#### **Floteq Pumps (Shanghai) Co.,Ltd**

Room 2005, Block A, No. 1301 Gonghe Xin Road,  
Jing 'an District, Shanghai, P.R.China  
Post code: 200040  
Tel : (86) 21 56067977

*All technical information is subject to change without prior notice.*

All rights (are) reserved.  
FTQ-XM-A-E-082024-01



[www.floteq.com](http://www.floteq.com)

## About FLOTEQ

**FLOTEQ** brand originated in Singapore.

Since 1981, started to produce vertical and horizontal multistage, submersible drainage and deepwell submersible centrifugal pumps. Since 1987, produced end suction centrifugal pump and single stage in-line centrifugal pump, for export markets in Europe and USA.

FLOTEQ Singapore Pte. Ltd., established in Singapore in 2014 with a team of more than 50 years of pump and pumping systems experiences.

FLOTEQ Pumps (Shanghai) Co., Ltd was established in 2014, to develop market and FLOTEQ brand in China, providing product application and support, sales and after sales service.

FLOTEQ Pumps (Wuxi) Co., Ltd was established in 2015, responsible for product assembly, testing, certification, warehousing and logistics services.

FLOTEQ Pumps (Malaysia) was established in 2020, to provide product sales, assembly and after-sales service in Malaysia, Brunei and Singapore.

FLOTEQ management places great emphasis on Total Quality Management, operation excellent and lean production. The complete “Production - Supply chain - Sales” process is applied and implemented so as to excel through FLOTEQ product and services.

FLOTEQ's core competitive business include high efficiency pumps and advance control system, energy saving water supply system, HVAC and various industrial water system.

FLOTEQ aspire to provide professional, practical and environmentally friendly pumps and pumping system solutions towards a better and comfortable lifestyle.



### Mission

*To provide solutions to pumping systems with professional service, pragmatic and environmentally friendly approach, always*



### Vision

*Improving and achieving better pumping systems through better understanding of customers’ needs and always have environmentally friendly thought in mind in our solutions.*



### Core Value

*Trust > Knowledge > loyalty*

## Content

Page	Parameters
02	Performance Range
03	Product Description
04-05	Motor
06-07	Maximum Inlet and Operating Pressure
08-11	Sectional View and Material
	Dimension Drawing、 Performance Curves
12-13	XM/XMI/XMN 1
14-15	XM/XMI/XMN 3
16-17	XM/XMI/XMN 5
18-19	XM/XMI/XMN 10
20-21	XM/XMI/XMN 15
22-23	XM/XMI/XMN 20
24-25	XM/XMI/XMN 32
26-27	XM/XMI/XMN 45
28-29	XM/XMI/XMN 64
30-31	XM/XMI/XMN 90
32-33	XM/XMI/XMN 120
34-35	XM/XMI/XMN 150

## Performance Range

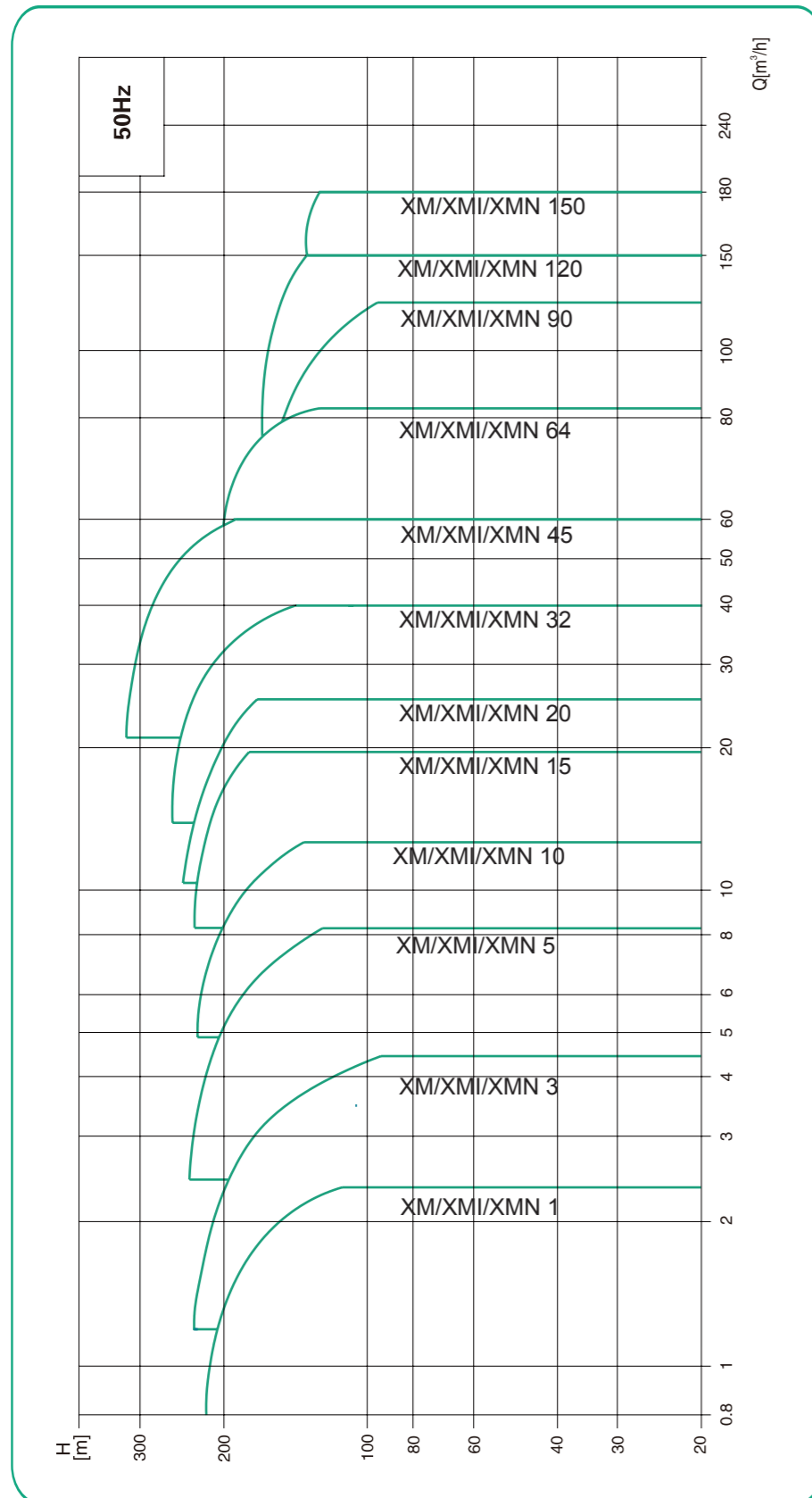

## Product Description

The XM/XMI/XMN series are of non-self priming, vertical in-line design which has equal size suction/discharge flange connections. The pumps are directly coupled to squirrel cage TEFC high efficiency electric motor. The XM/XMI/XMN range offers pumps with reliable performance and high efficiency that can be suitable for various industrial and commercial applications. The XM/XMI/XMN pump range is available in cast iron and stainless steel material construction with various flow sizes, capable of more than 20 bar pressure, and all pumps are equipped with a cartridge type mechanical seal for service friendly maintenance.

## Applications

The XM/XMI/XMN pumps are suitable for various applications, ranging from commercial buildings water supply to industrial broad-based usage. These include: water transfer systems, process water systems, washing and cleaning systems, fire-fighting systems, water treatment, boiler feed, and applications involving heating, ventilations and air-conditioning systems. The vertical multistage pumps design simply has its advantage best adapted for limited space usage as well as providing easy maintenance service.

## Features and benefits

- Quality and reliability built with precision parts
- Stainless steel parts resistant against abrasion and improve efficiency.
- Vertical in line design help to save installation space.
- Modular designs ensures service friendly replacement and ease of maintenance

## Pump Efficiency/Material

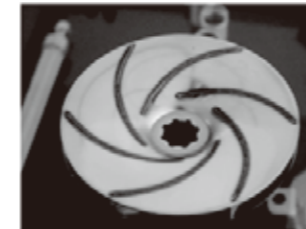

Pump efficiency are significantly increased via our high performance hydraulic design and precision production technology for stainless steel material. The XM/XMI/XMN series are available in cast iron/stainless steel material for different pumping media.  
 XM: cast iron/stainless steel material suitable for clean or non aggressive liquid  
 XMI: stainless steel AISI304 material for mild aggressive liquid.  
 XMN: stainless steel AISI316 material for aggressive liquid.

## Mechanical Seal



All pumps are equipped with a cartridge mechanical seal with hard wearing seal faces (silicon carbide vs silicon carbide) for durability and easy maintenance. Other materials are also available to suit the pumping pressure and liquid medium operating conditions. The cartridge design also enables rapid replacement to minimize downtime. The standard material of the O-ring is EPDM.

## Identification Code

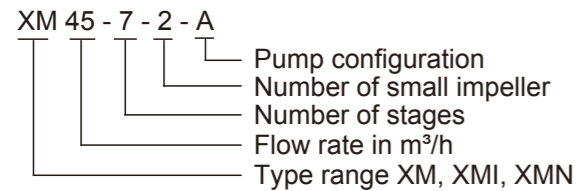

XM: The base and pump cover are made of cast iron

XMI: Flow passage components 304 stainless steel

XMN: Flow passage components 316 stainless steel

## Ambient Temperature

When the ambient temperature exceed 40°C or the installation altitude exceed 1000 m, the motor horsepower (P2) output must be derated to compensate for less effective cooling. If under this condition, we need to derate and increase the motor horsepower. Refer to the below chart for motor horsepower deration.

## Motor Horsepower (P2) deration chart

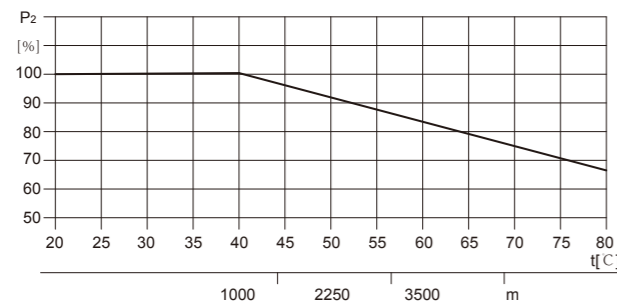

## Operating Conditions

The XM/XMI/XMN pumps are suitable for use under following operating conditions:

Liquid temperature: -20°C to 120°C

Highest ambient temperature: 40°C

Maximum Altitude (without duration): 1000 m

## Electric Motor

All Electric motors are of squirrel cage, totally enclosed fan cooled (TEFC) design, the motor have efficiency values that are according to high efficiency standard complying to IEC 60034-30-1

Motors are designed for operation as below:

2.2 kW and below: 1 x 220-240V, 50Hz  
3 x 220-240V/380-415V, 50Hz

3 kW and above: 3 x 380-415V, 50 Hz

Ingress Protection: IP55

Insulation class: F (other insulation class available on request)

Motor ambient temperature rating: Max 40° C

## IE2 Motor

Motor Type				Nominal current in [A]				
HP	kW	Pole	Flange	Frame	3~220V	3~240V	3~380V	3~415V
0.5	0.37	2	V18	71A	1.8	1.9	1	1.1
0.75	0.55			71B	2.6	2.7	1.5	1.6
1	0.75			80A	3.1	2.8	1.8	1.6
1.5	1.1			80B	4.4	4	2.5	2.3
2	1.5			90S	5.8	5.3	3.3	3.1
3	2.2			90L	8.2	7.5	4.7	4.3
4	3			100L	10.7	9.8	6.2	5.7
5.5	4			112M	13.9	NA	8	7.4
7.5	5.5		132S	V1	NA	NA	10.9	10
10	7.5		132S				14.5	13.3
15	11		160M				21	19.2
20	15		160M				28.4	26
25	18.5		160L				34.7	31.8
30	22		180M				41.1	37.7
40	30		200L				55.7	51
50	37		200L				68.3	62.5
60	45	225M	82.7				75.7	
75	55	250M	100.7				92.2	
100	75	280S	136.5				125	

## IE3 Motor

Motor Type				Nominal current in [A]				
HP	kW	Pole	Flange	Frame	3~220V	3~240V	3~380V	3~415V
1	0.75	2	V18	80A	3	2.7	1.7	1.6
1.5	1.1			80B	4.2	3.9	2.4	2.2
2	1.5			90S	5.6	5.1	3.2	3
3	2.2			90L	7.9	7.2	4.6	4.2
4	3			100L	10.4	9.5	6	5.5
5.5	4			112M	13.5	15	7.8	7.2
7.5	5.5		132S	V1	NA	NA	10.6	9.7
10	7.5		132S				14.2	13
15	11		160M				20.6	18.9
20	15		160M				27.9	25.5
25	18.5		160L				34.2	31.3
30	22		180M				40.5	37.1
40	30		200L				54.9	50.3
50	37		200L				67.4	61.7
60	45		225M				80.8	74
75	55		250M				98.5	90.2
100	75	280S	133.7	122.4				

Subject to change without our prior notice, as and when other motor brands are involved.

## Minimum Pump Inlet Pressure - NPSH

It is recommended to calculate the suction inlet pressure when the following conditions exist :

High liquid temperature

The flow rate is obviously higher than the rated flow rate

Negative suction with water level lower than the pump's inlet

Suction pipe total length with more than 20 meters

Big fluctuation of suction water level or liquid temperature at site

### Vapour Pressure Equivalent In Meter Head

To avoid cavitation, a minimum pressure must be available on the inlet side of the pump

The maximum suction height "H" can be calculated according to the following formula:

$$H = P_b \times 10.2 - (NPSH_r + H_f + H_v + H_s)$$

$P_b$ : Atmospheric pressure bar (Atmospheric pressure was set at 1 bar)  
In a closed system,  $P_b$  is the system pressure

$NPSH_r$ : Net positive suction head required by pump [ m ]

$H_f$ : Friction loss of suction line [ m ]

$H_v$ : Vapour pressure [ m ]

$H_s$ : Safety margin (min. 1m)

If H is positive, this denote the maximum suction lift allowed  
If H is negative, we need to reselect pump with lower  $NPSH_r$

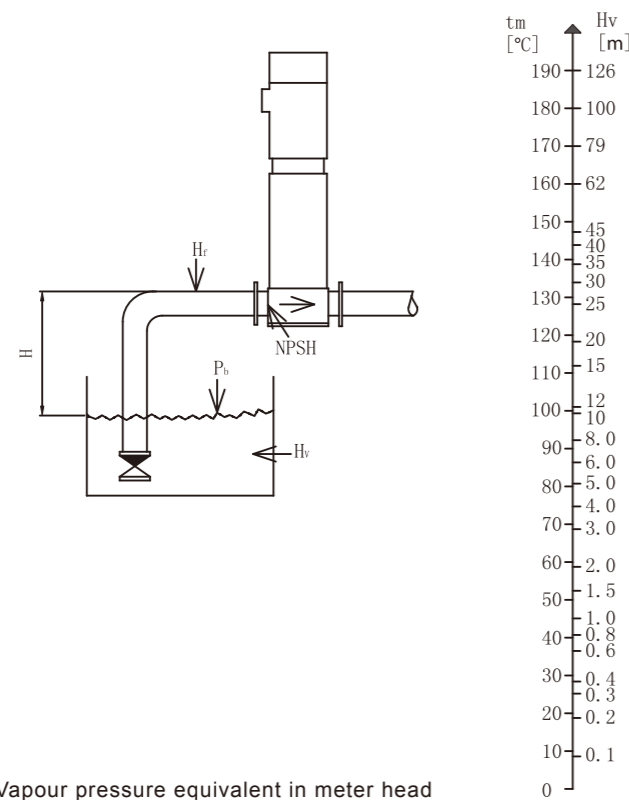

In order to avoid cavitation, the rated point of the pump should be selected away from the right side of the NPSH curve. Always check the NPSH value of the pump at the highest possible flow rate.

## Maximum Inlet and Operating Pressure

### Maximum Inlet Pressure

Note: Pump inlet pressure + pump closed valve pressure must be less than the pump maximum working pressure rating to prevent damages to the pump. The table below indicate the pump maximum inlet pressure:

Pump Model	Maximum inlet pressure(Bar)
XM(I/N) 1-2 - 1-36	10
XM(I/N) 3-2 - 3-29	10
XM(I/N) 3-31 - 3-36	15
XM(I/N) 5-2 - 5-16	10
XM(I/N) 5-18 - 5-29	15
XM(I/N) 10-1 - 10-6	8
XM(I/N) 10-7 - 10-22	10
XM(I/N) 15-1 - 15-3	8
XM(I/N) 15-4 - 15-17	10
XM(I/N) 20-1 - 20-3	8
XM(I/N) 20-4 - 20-17	10
XM(I/N) 32-1-1 - 32-4	4
XM(I/N) 32-5-2 - 32-10	10
XM(I/N) 32-11 - 32-14	15
XM(I/N) 45-1-1 - 45-2	4
XM(I/N) 45-3-2 - 45-5	10
XM(I/N) 45-6-2 - 45-13-2	15
XM(I/N) 64-1-1 - 64-2-2	4
XM(I/N) 64-2-1 - 64-4-2	10
XM(I/N) 64-4-1 - 64-8-1	15
XM(I/N) 90-1-1 - 90-1	4
XM(I/N) 90-2-2 - 90-3-2	10
XM(I/N) 90-3 - 90-6	15
XM(I/N) 120-1 - 120-2-1	10
XM(I/N) 120-2 - 120-5-1	15
XM(I/N) 120-5 - 120-7	20
XM(I/N) 150-1-1 - 150-2-2	10
XM(I/N) 150-2-1 - 150-4-1	15
XM(I/N) 150-4 - 150-6	20

### Maximum Operating Pressure

Pump Model	Maximum Operating Pressure(Bar)
	DIN Flange
XM(I/N) 1	25
XM(I/N) 3	25
XM(I/N) 5	25
XM(I/N) 10	25
XM(I/N) 15	25
XM(I/N) 20	25
XM(I/N) 32-1-1 - 32-7	16
XM(I/N) 32-8-2 - 32-14	30
XM(I/N) 45-1-1 - 45-5	16
XM(I/N) 45-6-2 - 45-11	30
XM(I/N) 45-12-2 - 45-13-2	33
XM(I/N) 64-1-1 - 64-5	16
XM(I/N) 64-6-2 - 64-8-1	30
XM(I/N) 90-1-1 - 90-4	16
XM(I/N) 90-5-2 - 90-6	30
XM(I/N) 120-1 - 120-7	30
XM(I/N) 150-1-1 - 150-6	30

### Sectional View and Material

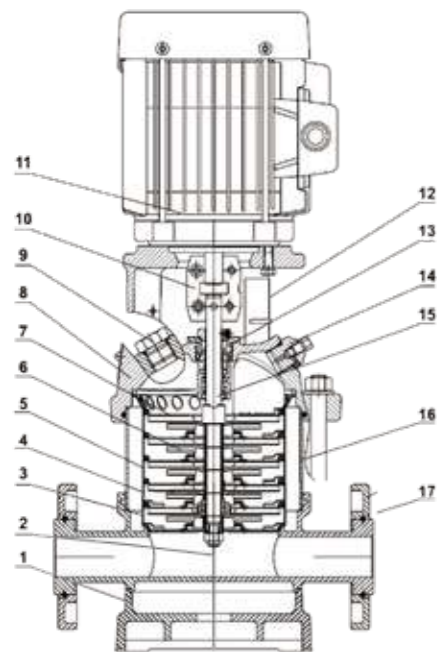

**Model: XM 1/3/5**

No.	Part	Material
1	Base	HT200
2	Drainage plug assembly	AISI304
3	Primary diffuser	AISI304
4	Diffuser with bearing	AISI304
5	Medium diffuser	AISI304
6	Impeller	AISI304
7	Final diffuser	AISI304
8	Motor base	HT200
9	Filling plug	AISI304
10	Coupling	Iron based powder metallurgy
11	Motor	-
12	Guarding plate	AISI304
13	Mech seal	Cartridge seal
14	Vent plug assembly	AISI304
15	Pump shaft	AISI304
16	Pump barrel	AISI304
17	Flange	HT200

### Sectional View and Material

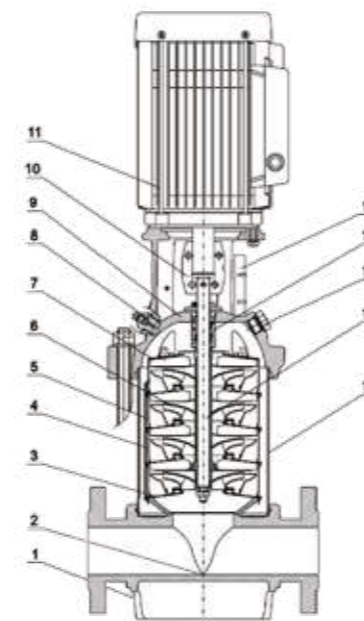

**Model: XM 10/15/20**

No.	Part	Material
1	Base	HT200
2	Drainage plug assembly	AISI304
3	Primary diffuser	AISI304
4	Diffuser with bearing	AISI304
5	Medium diffuser	AISI304
6	Impeller	AISI304
7	Final diffuser	AISI304
8	Filling plug	AISI304
9	Motor base	HT200
10	Coupling	Iron based powder metallurgy
11	Motor	-
12	Guarding plate	AISI304
13	Mech seal	Cartridge seal
14	Vent plug assembly	AISI304
15	Pump shaft	AISI304
16	Pump barrel	AISI304

**Model: XMI/XMN 1/3/5**

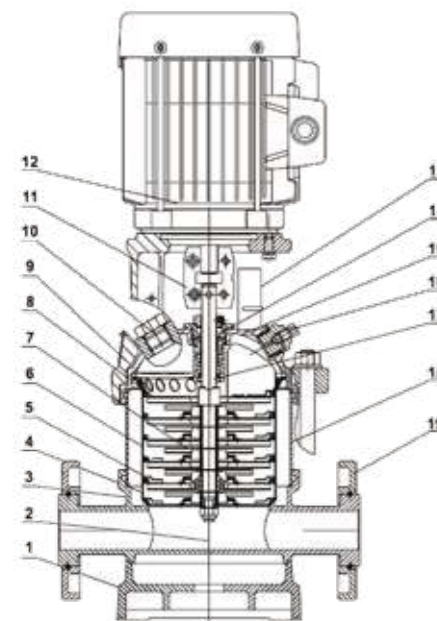

No.	Part	Material	
		XMI	XMN
1	Base plate	HT200	
2	Drainage plug assembly	AISI304	AISI 316
3	Pump base	AISI304	AISI 316
4	Primary diffuser	AISI304	AISI 316
5	Diffuser with bearing	AISI304	AISI 316
6	Medium diffuser	AISI304	AISI 316
7	Impeller	AISI304	AISI 316
8	Final diffuser	AISI304	AISI 316
9	Motor base	HT200	
10	Filling plug	AISI304	AISI 316
11	Coupling	Iron based powder metallurgy	
12	Motor	-	
13	Guarding plate	AISI304	
14	Mech seal	Cartridge seal	
15	Pump cover	AISI304	AISI 316
16	Vent plug assembly	AISI304	AISI 316
17	Pump shaft	AISI304	AISI 316
18	Pump barrel	AISI304	AISI 316
19	Flange	ZG35	

**Model: XMI/XMN 10/15/20**

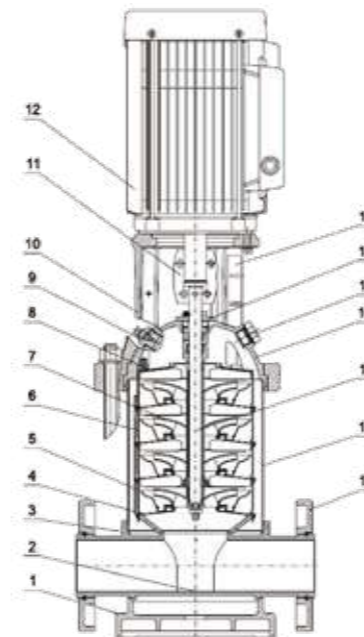

No.	Part	Material	
		XMI	XMN
1	Base plate	HT200	
2	Drainage plug assembly	AISI304	AISI 316
3	Pump base	AISI304	AISI 316
4	Primary diffuser	AISI304	AISI 316
5	Diffuser with bearing	AISI304	AISI 316
6	Medium diffuser	AISI304	AISI 316
7	Impeller	AISI304	AISI 316
8	Final diffuser	AISI304	AISI 316
9	Filling plug	AISI304	AISI 316
10	Motor base	HT200	
11	Coupling	Iron based powder metallurgy	
12	Motor	-	
13	Guarding plate	AISI304	
14	Mech seal	Cartridge seal	
15	Vent plug assembly	AISI304	AISI 316
16	Pump cover	AISI304	AISI 316
17	Pump shaft	AISI304	AISI 316
18	Pump barrel	AISI304	AISI 316
19	Flange	ZG35	

### Sectional View and Material

**Model: XM 32/45/64/90**

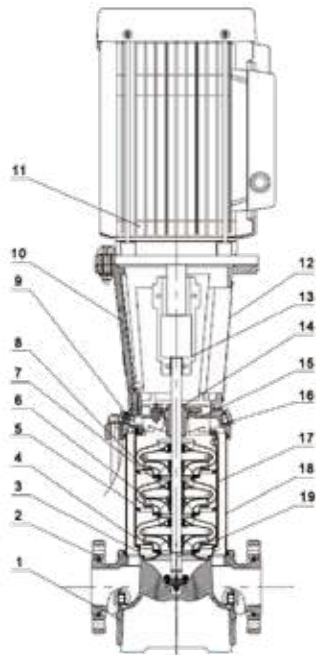

No.	Part	Material
1	Base plate	HT200
2	Flange	ZG35
3	Primary diffuser	AISI304
4	Medium diffuser	AISI304
5	Diffuser with bearing	AISI304
6	Impeller	AISI304
7	Shaft sleeve assembly	-
8	Final diffuser	AISI304
9	Vent plug assembly	AISI304
10	Motor base	HT200
11	Motor	-
12	Guarding plate	AISI304
13	Coupling	QT400
14	Mech seal	Cartridge seal
15	Pump head	HT200
16	Filling plug	AISI304
17	Tension plate	AISI304
18	Pump barrel	AISI304
19	Pump shaft	AISI304

### Sectional View and Material

**Model: XM 120/150**

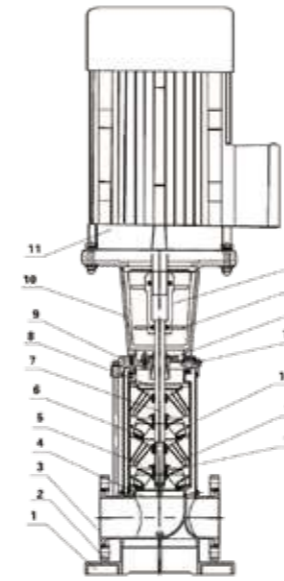

No.	Part	Material
1	Base plate	HT200
2	Flange	ZG35
3	Pump base	HT200
4	Primary diffuser	AISI304
5	Medium diffuser	AISI304
6	Diffuser with bearing	AISI304
7	Impeller	AISI304
8	Final diffuser	AISI304
9	Pump head	HT200
10	Motor base	HT200
11	Motor	-
12	Coupling	QT400
13	Guarding plate	AISI304
14	Mech seal	Cartridge seal
15	Filling plug	AISI304
16	Tension plate	AISI304
17	Pump barrel	AISI304
18	Pump shaft	AISI304

**Model: XMI/XMN 32/45/64/90**

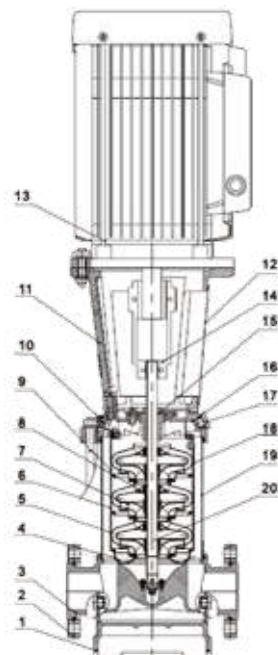

No.	Part	Material	
		XMI	XMN
1	Base plate	HT200	
2	Flange	ZG35	
3	Pump base	AISI304	AISI 316
4	Primary diffuser	AISI304	AISI 316
5	Medium diffuser	AISI304	AISI 316
6	Diffuser with bearing	AISI304	AISI 316
7	Impeller	AISI304	AISI 316
8	Shaft sleeve assembly	-	
9	Final diffuser	AISI304	AISI 316
10	Vent plug assembly	AISI304	AISI 316
11	Motor base	HT200	
12	Guarding plate	AISI304	
13	Motor	-	
14	Coupling	QT400	
15	Mech seal	Cartridge seal	
16	Pump head	AISI304	AISI 316
17	Filling plug	AISI304	AISI 316
18	Tension plate	AISI304	AISI 316
19	Pump barrel	AISI304	AISI 316
20	Pump shaft	AISI304	AISI 316

**Model: XMI/XMN 120/150**

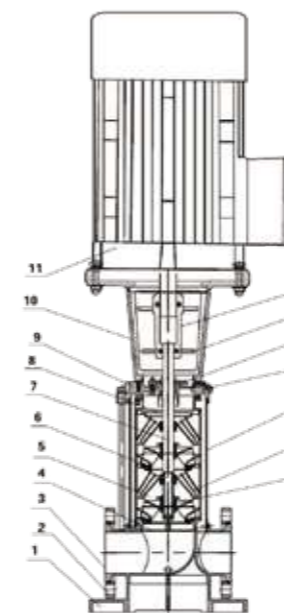

No.	Part	Material	
		XMI	XMN
1	Base plate	HT200	
2	Flange	ZG35	
3	Pump base	HT200	AISI 316
4	Primary diffuser	AISI304	AISI 316
5	Medium diffuser	AISI304	AISI 316
6	Diffuser with bearing	AISI304	AISI 316
7	Impeller	AISI304	AISI 316
8	Final diffuser	AISI304	AISI 316
9	Pump head	AISI304	AISI 316
10	Motor base	HT200	
11	Motor	-	
12	Coupling	QT400	
13	Guarding plate	AISI304	
14	Mech seal	Cartridge seal	
15	Filling plug	AISI304	AISI 316
16	Tension plate	AISI304	AISI 316
17	Pump barrel	AISI304	AISI 316
18	Pump shaft	AISI304	AISI 316

### Performance Curves

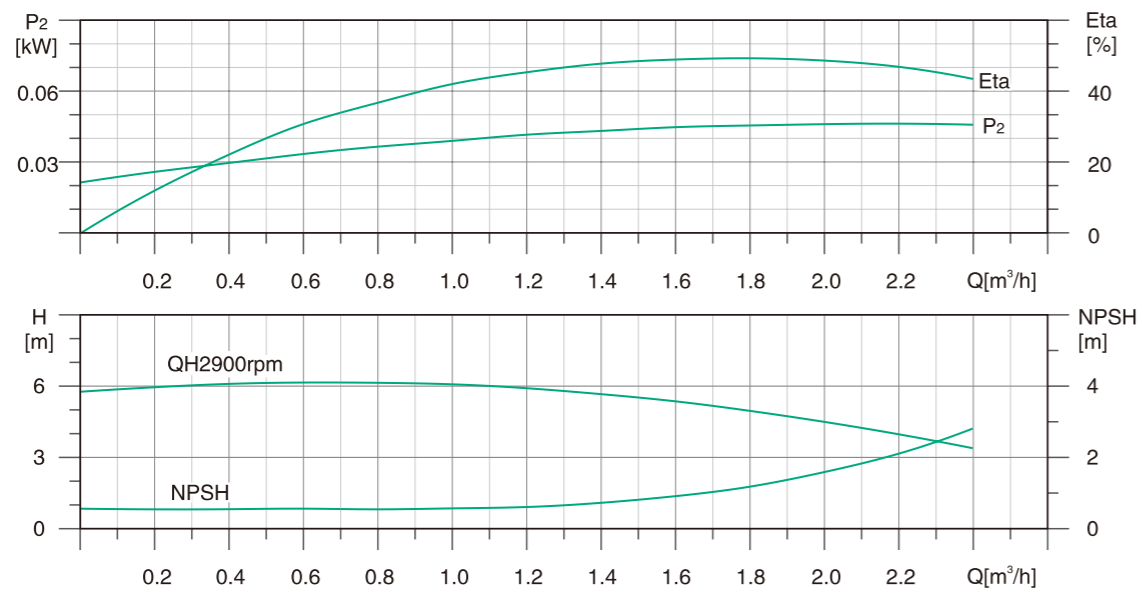
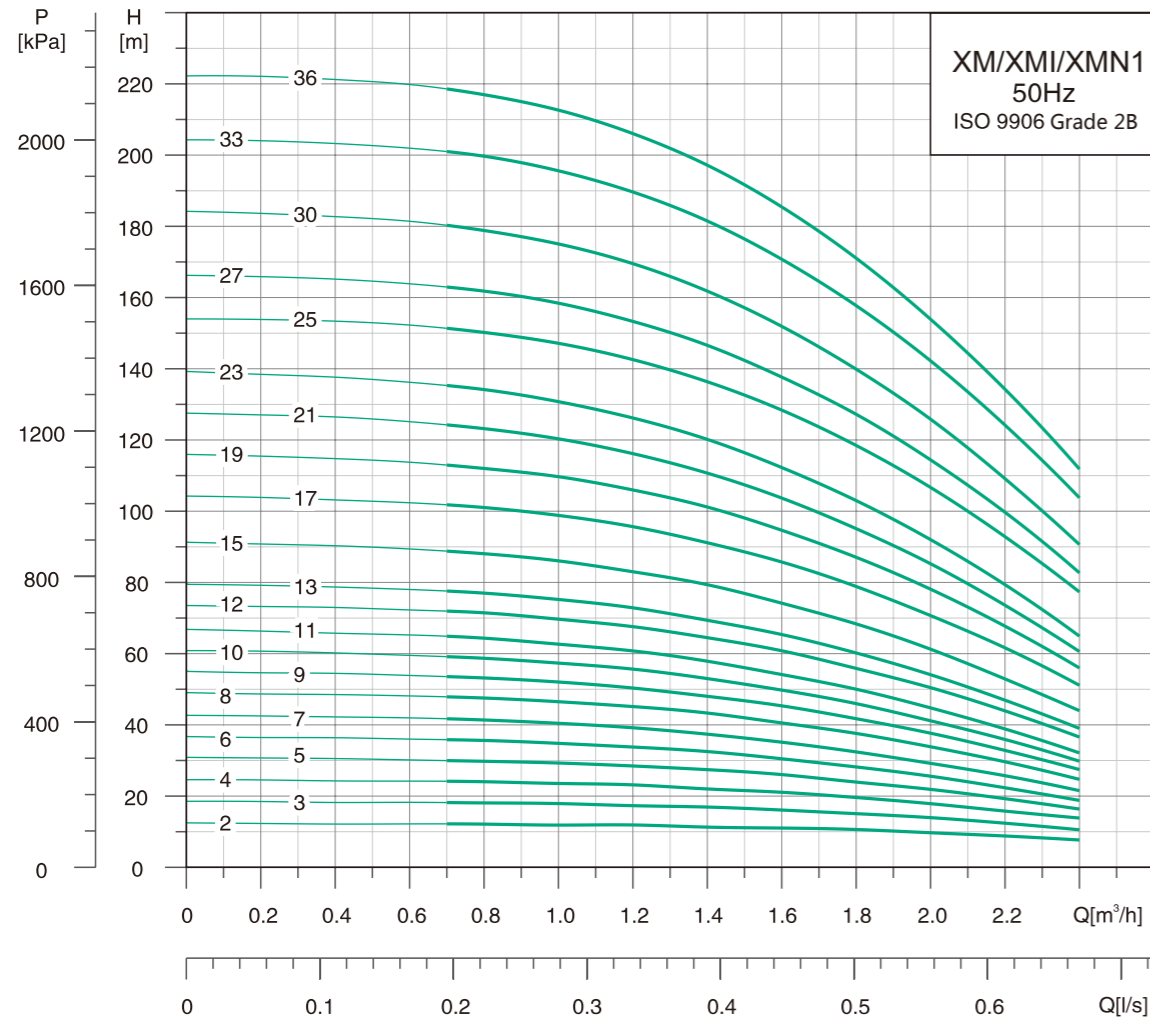

### Dimension Drawing

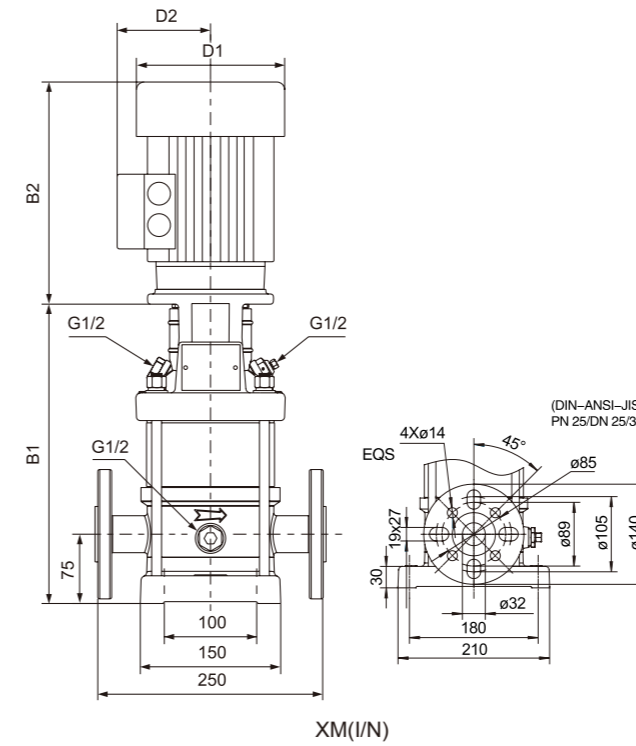

Model	DIN FLANGE XM(I/N)		D1	D2	Net Weight (kg)	
	B1	B1+B2			XM	XMI/N
XM(I/N)1-2	282	496	130	105	20.4	20.4
XM(I/N)1-3	282	496	130	105	20.8	21.2
XM(I/N)1-4	300	514	130	84	21.2	21.8
XM(I/N)1-5	318	532	130	84	21.7	22.4
XM(I/N)1-6	336	550	130	84	22.2	22.4
XM(I/N)1-7	354	568	130	84	22.4	22.6
XM(I/N)1-8	372	586	130	84	23.9	24.4
XM(I/N)1-9	390	604	130	84	23.9	24.7
XM(I/N)1-10	408	622	130	84	24.7	27.8
XM(I/N)1-11	426	640	130	84	25.1	25.5
XM(I/N)1-12	448	716	150	124.5	27.7	27.8
XM(I/N)1-13	466	734	150	124.5	27.8	28.2
XM(I/N)1-15	502	770	150	124.5	29.1	29.0
XM(I/N)1-17	538	806	150	124.5	31.5	30.3
XM(I/N)1-19	574	842	150	124.5	33.0	31.8
XM(I/N)1-21	610	878	150	124.5	33.3	31.8
XM(I/N)1-23	646	914	150	124.5	34.9	32.7
XM(I/N)1-25	698	1016	163.6	127.4	41.4	41.3
XM(I/N)1-27	734	1052	163.6	127.4	43.5	43.1
XM(I/N)1-30	788	1106	163.6	127.4	43.1	43.8
XM(I/N)1-33	842	1160	163.6	127.4	46.9	45.4
XM(I/N)1-36	896	1214	163.6	127.4	47.9	47.5

Model	Power (kW)	Q (m³/h)	H (m)											
			0.7	0.8	1.0	1.2	1.4	1.6	1.8	2.0	2.2	2.4		
XM(I/N)1-2	0.37		12	12	12	12	11	11	10	10	9	8		
XM(I/N)1-3	0.37		18	18	18	17	17	16	15	14	13	10.5		
XM(I/N)1-4	0.37		24	24	24	22	22	21	19	18	15	14		
XM(I/N)1-5	0.37		30	30	29.5	28	27	26	24	22	19	16		
XM(I/N)1-6	0.37		36	35	35	34	32	30	28	25	22	19		
XM(I/N)1-7	0.37		42	41	40.5	39	37	35	32	30	26	22		
XM(I/N)1-8	0.55		48	47	46.5	45	43	40	38	34	30	26		
XM(I/N)1-9	0.55		54	53	52	50	48	45	42	37	33	28		
XM(I/N)1-10	0.55		59	58	57.5	55	53	50	46	41	35	30		
XM(I/N)1-11	0.55		65	64	63	61	58	54	51	45	39	33		
XM(I/N)1-12	0.75		72	71	70	67	64	61	56	50	44	37		
XM(I/N)1-13	0.75		78	77	75	73	69	65	60	54	48	39.5		
XM(I/N)1-15	0.75		90	88	86	83	79	74	68	61	54	45		
XM(I/N)1-17	1.1		102	101	98	95	91	85	78	70	62	52		
XM(I/N)1-19	1.1		114	112	110	106	101	94	87	78	68	57		
XM(I/N)1-21	1.1		125	123	120	116	110	103	95	85	74	61		
XM(I/N)1-23	1.1		136	134	130	126	120	112	103	92	80	65		
XM(I/N)1-25	1.5		152	150	145	142	136	128	119	106	93	78		
XM(I/N)1-27	1.5		164	162	157	153	146	137	128	114	100	84		
XM(I/N)1-30	1.5		181	178	173	169	162	152	140	126	110	92		
XM(I/N)1-33	2.2		202	199	194	189	181	170	158	142	124	106		
XM(I/N)1-36	2.2		220	217	210	206	197	185	170	154	135	112		

### Performance Curves

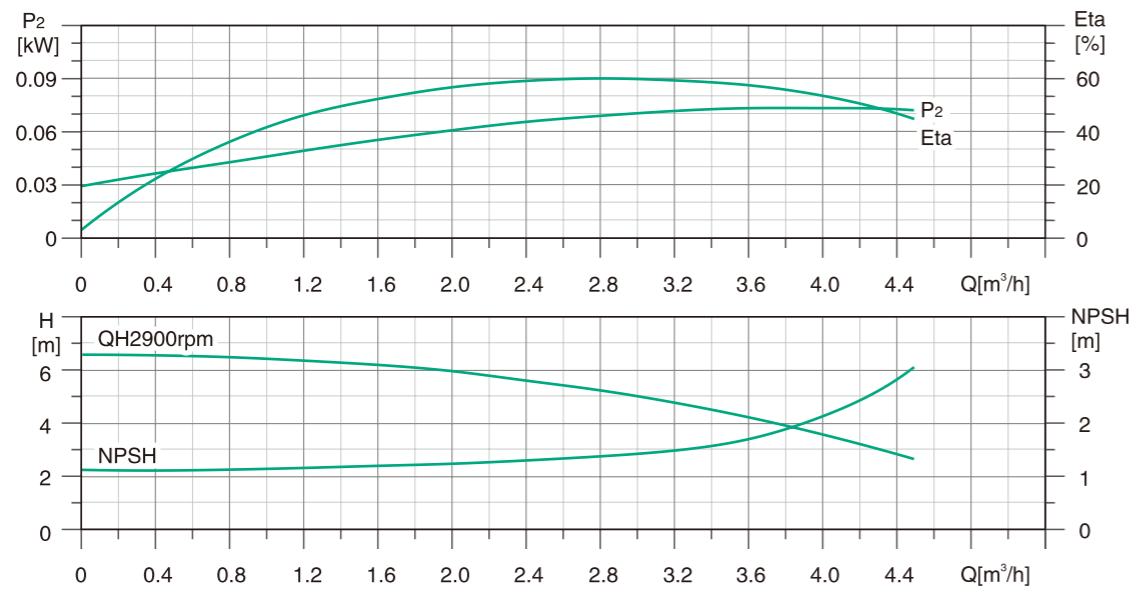
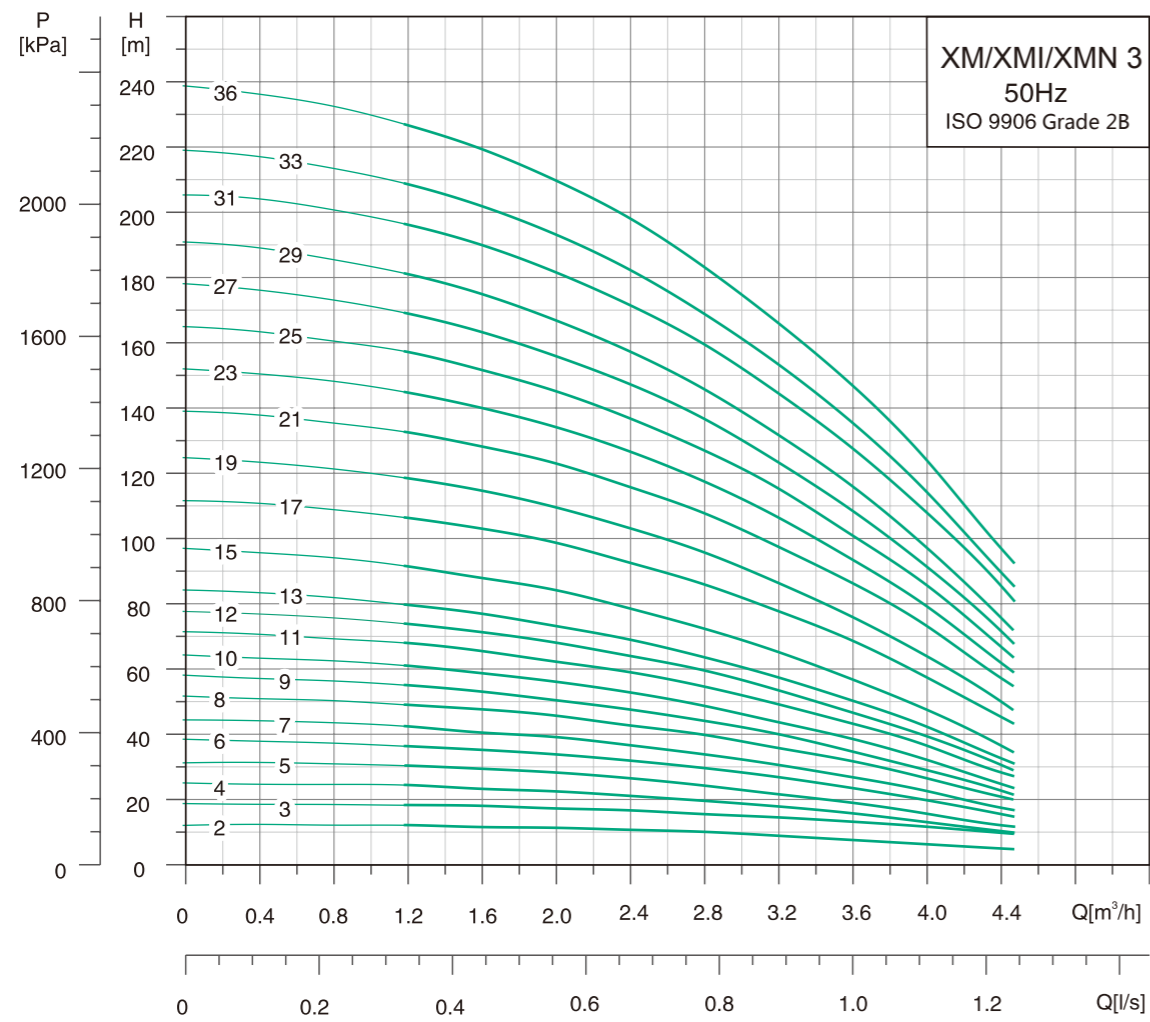

### Dimension Drawing

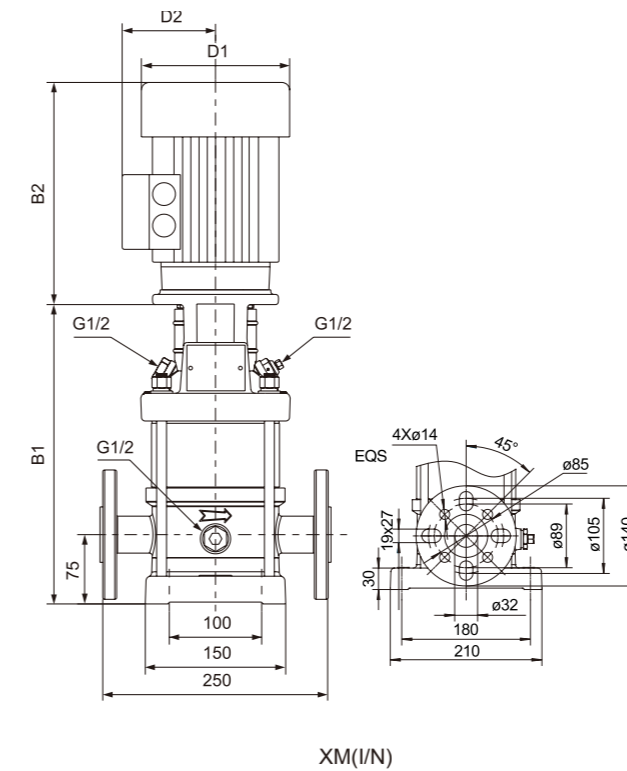

Model	DIN FLANGE XM(I/N)		D1	D2	Net Weight (kg)	
	B1	B1+B2			XM	XMI/N
	Dimension [mm]					
XM(I/N)3-2	282	496	130	105	20.6	21.0
XM(I/N)3-3	282	496	130	105	21.0	21.4
XM(I/N)3-4	300	514	130	105	21.4	21.8
XM(I/N)3-5	318	532	130	105	22.8	22.2
XM(I/N)3-6	336	550	130	105	23.2	23.2
XM(I/N)3-7	354	568	130	105	23.7	23.6
XM(I/N)3-8	376	644	150	124	25.0	25.5
XM(I/N)3-9	394	662	150	124	26.0	26.6
XM(I/N)3-10	412	680	150	124	27.0	27.2
XM(I/N)3-11	430	698	150	124	28.7	28.8
XM(I/N)3-12	448	716	150	124	29.4	29.7
XM(I/N)3-13	466	734	150	124	30.1	30.1
XM(I/N)3-15	502	770	150	124	32.1	30.7
XM(I/N)3-17	554	872	164	127	39.1	37.6
XM(I/N)3-19	590	908	164	127	40.1	39.0
XM(I/N)3-21	626	944	164	127	42.2	41.7
XM(I/N)3-23	662	980	164	127	42.4	42.4
XM(I/N)3-25	698	1016	164	127	44.4	43.4
XM(I/N)3-27	734	1052	164	127	44.5	44.4
XM(I/N)3-29	770	1088	164	127	45.3	44.7
XM(I/N)3-31	810	1150	186	120	52.3	52.1
XM(I/N)3-33	846	1186	186	120	53.1	52.6
XM(I/N)3-36	900	1240	186	120	54.7	53.8

Model	Power (kW)	Q (m³/h)	H (m)									
			1.2	1.6	2.0	2.4	2.8	3.0	3.6	4.0	4.5	
XM(I/N)3-2	0.37		13	12	12	11	11	10	8	7.5	4	
XM(I/N)3-3	0.37		19	19	18	17	16	15	14	12	8	
XM(I/N)3-4	0.37		25	24	23	22	20	19	17	14	9	
XM(I/N)3-5	0.37		31	31	29	27	25	24	20	17	11	
XM(I/N)3-6	0.55		37	36	35	33	30	28	24	21	14	
XM(I/N)3-7	0.55		43	40	40	37	35	32	28	24	16	
XM(I/N)3-8	0.75		51	48	47	44	41	38	33	28	19	
XM(I/N)3-9	0.75		56	54	51	48	45	42	36	30	21	
XM(I/N)3-10	0.75		62	60	57	54	50	46	40	33	23	
XM(I/N)3-11	1.1		69	66	63	60	56	51	44	38	26	
XM(I/N)3-12	1.1		75	72	69	65	61	56	48	41	28	
XM(I/N)3-13	1.1		80	78	74	70	65	60	51	44	30	
XM(I/N)3-15	1.1		92	89	85	80	73	68	58	49	34	
XM(I/N)3-17	1.5		107	104	100	94	87	78	70	59	42	
XM(I/N)3-19	1.5		119	116	111	104	97	87	77	65	47	
XM(I/N)3-21	2.2		133	129	124	117	109	97	88	75	54	
XM(I/N)3-23	2.2		146	141	135	128	119	105	95	81	59	
XM(I/N)3-25	2.2		158	153	146	138	128	115	102	87	64	
XM(I/N)3-27	2.2		170	164	157	148	138	124	110	93	67	
XM(I/N)3-29	2.2		182	176	168	159	147	133	118	100	72	
XM(I/N)3-31	3		197	191	183	173	161	142	128	110	80	
XM(I/N)3-33	3		210	203	194	194	170	152	137	116	84	
XM(I/N)3-36	3		228	221	211	200	185	165	149	126	91	

### Performance Curves

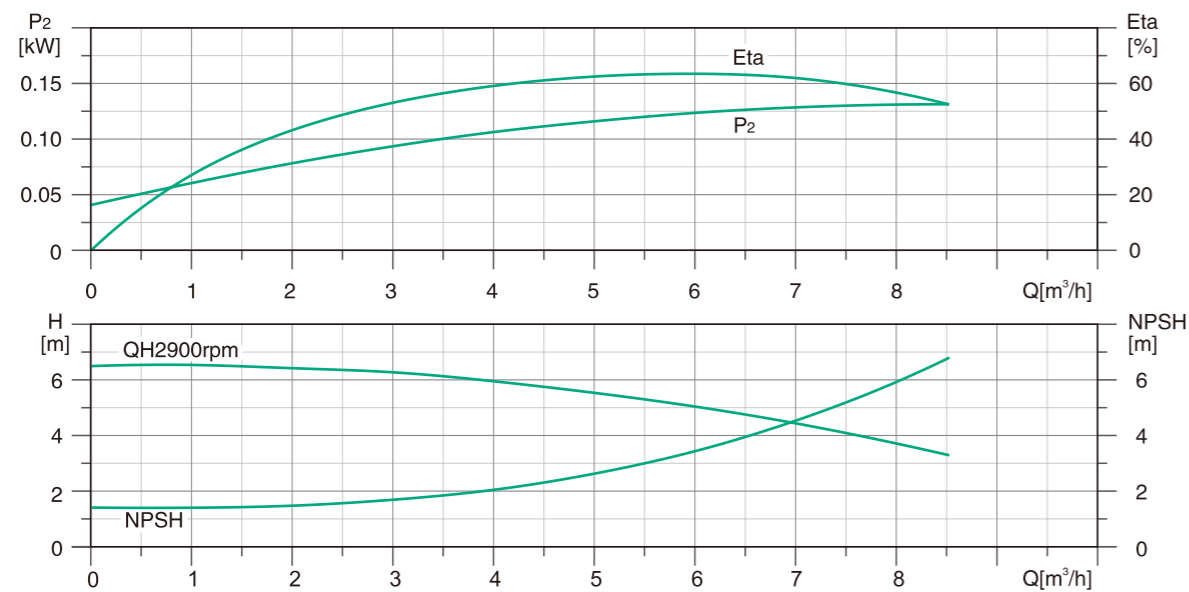
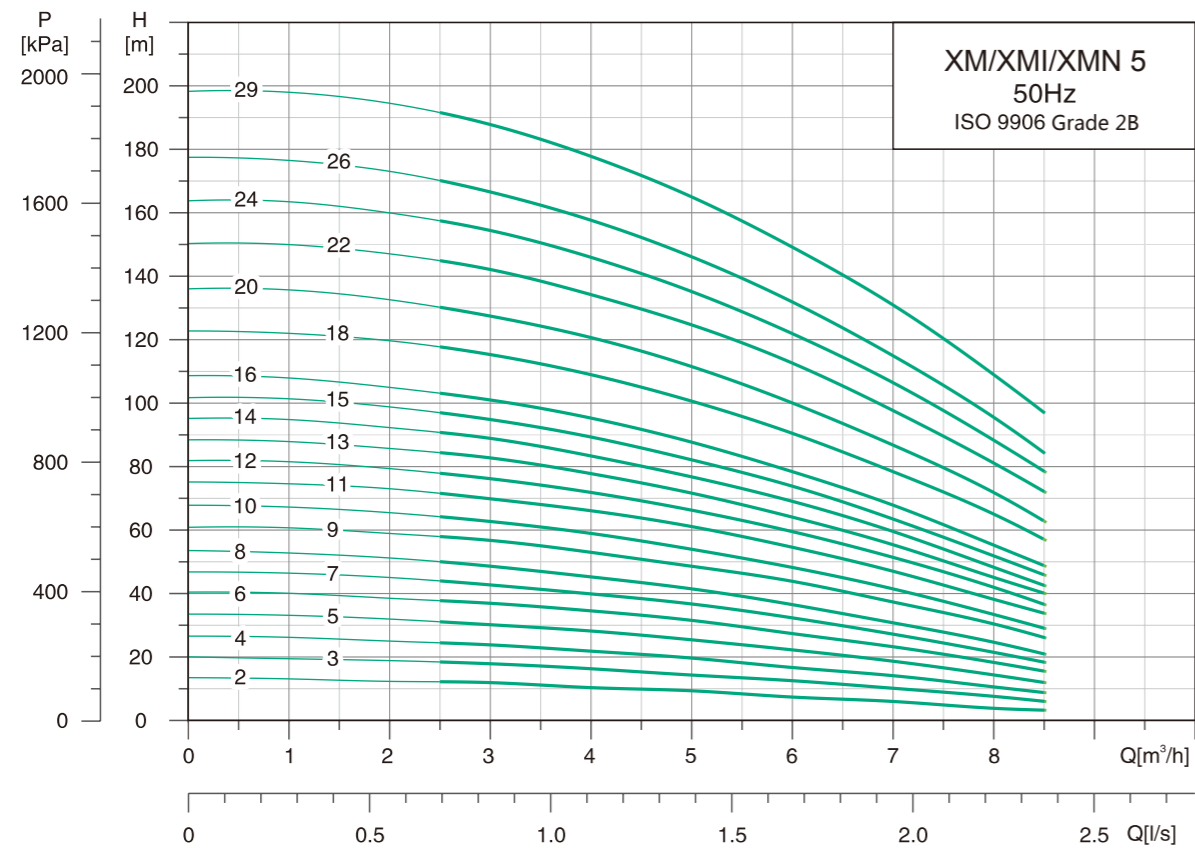

### Dimension Drawing

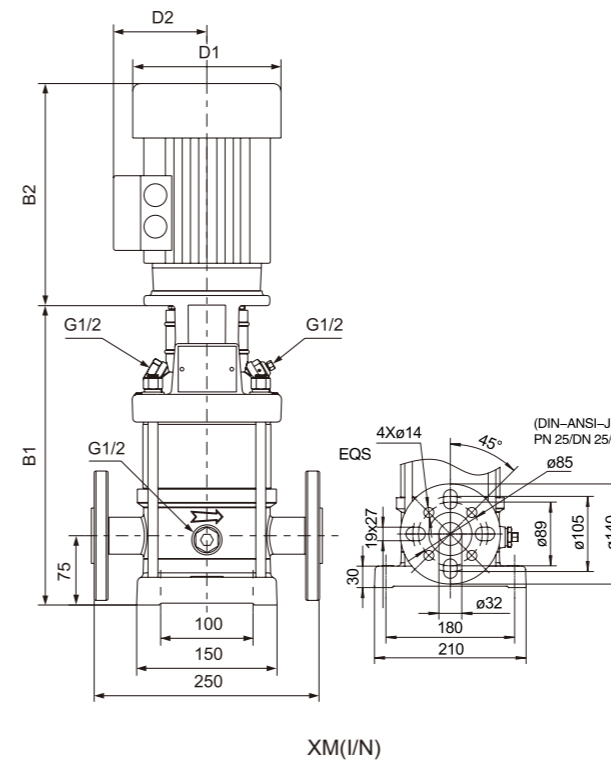

Model	DIN FLANGE XM(I/N)		D1	D2	Net Weight (kg)	
	B1	B1+B2			XM	XMI/N
	Dimension [mm]					
XM(I/N)5-2	282	496	130	105	20.9	20.6
XM(I/N)5-3	309	523	130	105	21.7	21.8
XM(I/N)5-4	336	550	130	105	22.7	22.4
XM(I/N)5-5	367	635	150	125	25.5	25.2
XM(I/N)5-6	394	662	150	125	27.6	26.8
XM(I/N)5-7	421	689	150	125	28.5	28.3
XM(I/N)5-8	448	716	150	125	29.1	29.1
XM(I/N)5-9	491	809	164	127	37.2	37.2
XM(I/N)5-10	518	836	164	127	37.8	37.6
XM(I/N)5-11	545	863	164	127	38.0	39.4
XM(I/N)5-12	572	890	164	127	39.9	39.6
XM(I/N)5-13	599	917	164	127	40.5	39.8
XM(I/N)5-14	626	944	164	127	40.9	40.8
XM(I/N)5-15	653	971	164	127	41.5	41.2
XM(I/N)5-16	680	998	164	127	42.4	42.4
XM(I/N)5-18	738	1078	186	120	49.9	48.3
XM(I/N)5-20	792	1132	186	120	51.3	48.9
XM(I/N)5-22	846	1186	186	120	54.1	53.9
XM(I/N)5-24	900	1240	186	120	55.4	55.3
XM(I/N)5-26	954	1294	186	120	57.1	56.9
XM(I/N)5-29	1035	1375	186	120	58.7	59.8

Model	Power (kW)	Q (m³/h)	H (m)								
			2.5	3.0	4.0	5.0	6.0	7.0	8.0	8.5	
XM(I/N)5-2	0.37		12	12	10	9	7	6	4	3.5	
XM(I/N)5-3	0.55		19	18	16	15	12	10	8	6	
XM(I/N)5-4	0.55		24	24	22	19	16	14	10.5	9	
XM(I/N)5-5	0.75		31	30	28	24	22	18	15	12	
XM(I/N)5-6	1.1		38	37	34	28	27	23	19	15	
XM(I/N)5-7	1.1		44	42	40	32	32	27	22	19	
XM(I/N)5-8	1.1		50	48	45	40	36	31	25	21	
XM(I/N)5-9	1.5		59	56	53	47	44	37	31	26	
XM(I/N)5-10	1.5		65	62	59	53	48	41	34	29	
XM(I/N)5-11	2.2		73	70	66	59	54	47	38	35	
XM(I/N)5-12	2.2		78	76	72	63	59	51	42	38	
XM(I/N)5-13	2.2		85	82	78	68	64	55	54	40	
XM(I/N)5-14	2.2		91	89	83	74	69	60	58	53	
XM(I/N)5-15	2.2		98	95	89	79	74	63	52	46	
XM(I/N)5-16	2.2		103	101	95	85	78	68	55	49	
XM(I/N)5-18	3		118	115	109	98	90	78	65	58	
XM(I/N)5-20	3		130	127	120	108	100	87	72	64	
XM(I/N)5-22	4		145	142	134	120	112	97	80	72	
XM(I/N)5-24	4		158	154	146	132	122	106	88	78	
XM(I/N)5-26	4		170	166	157	145	132	115	95	85	
XM(I/N)5-29	4		192	188	178	155	149	131	109	98	

### Performance Curves

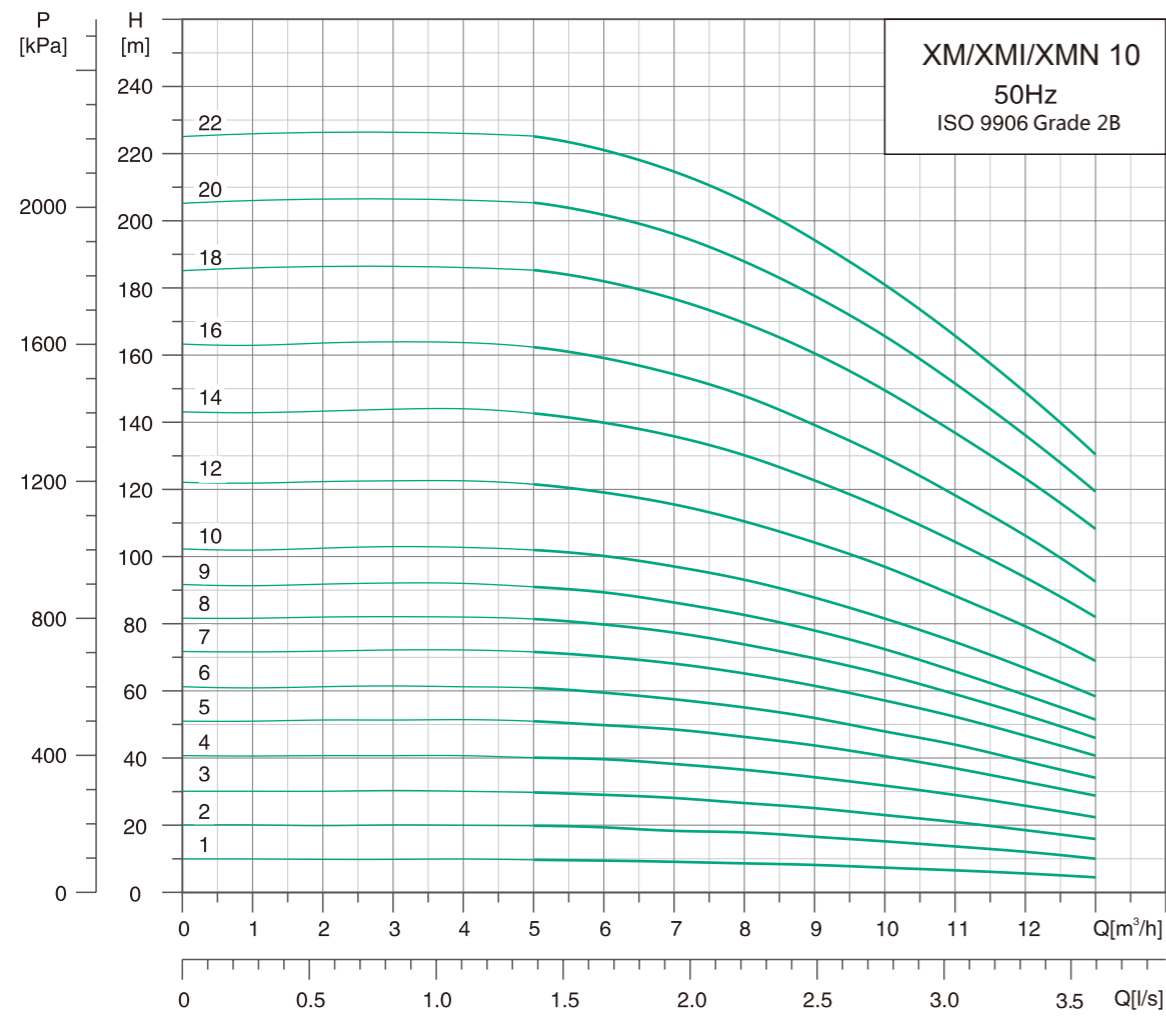

### Dimension Drawing

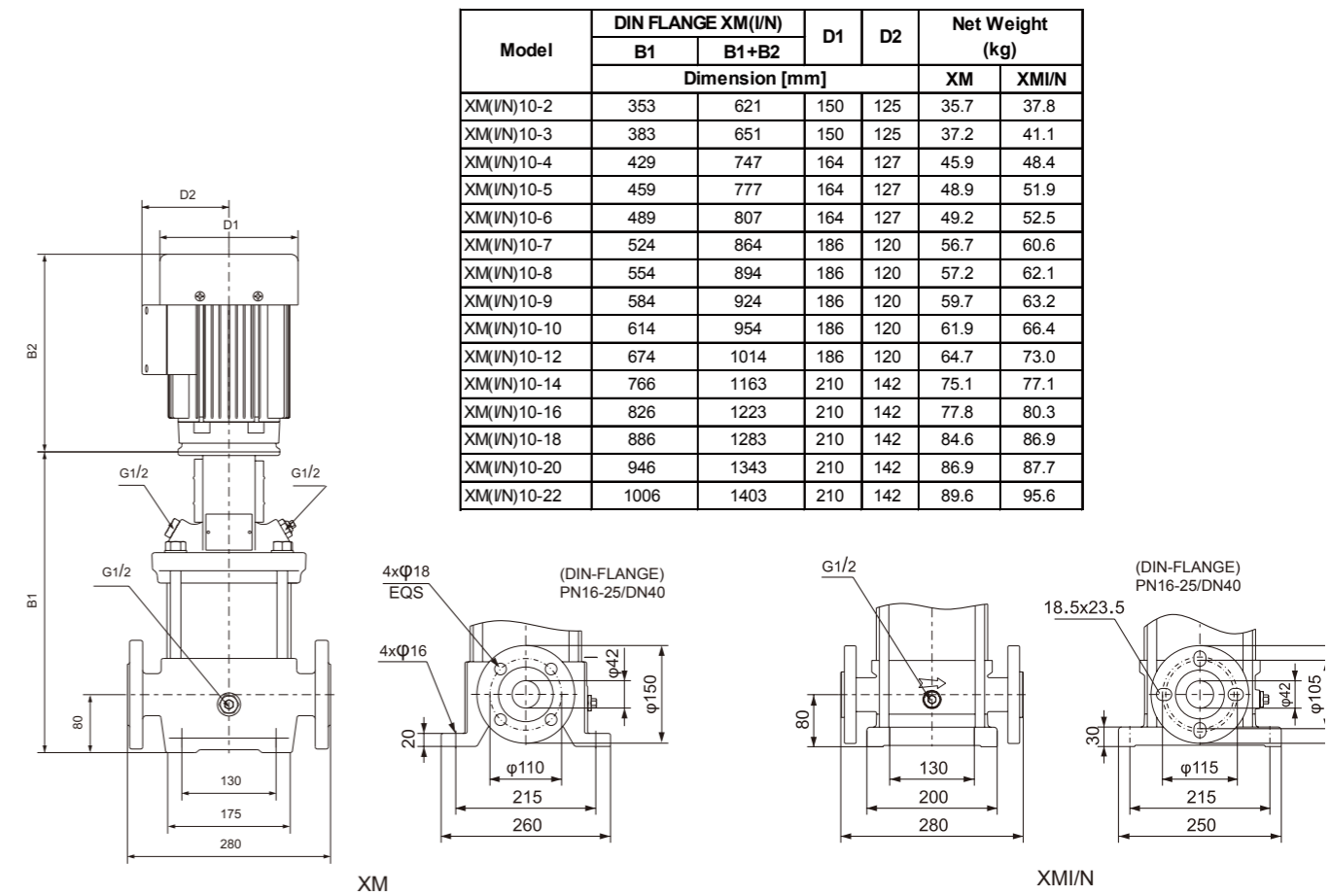

Model	DIN FLANGE XM(I/N)		D1	D2	Net Weight (kg)	
	B1	B1+B2			XM	XMI/N
XM(I/N)10-2	353	621	150	125	35.7	37.8
XM(I/N)10-3	383	651	150	125	37.2	41.1
XM(I/N)10-4	429	747	164	127	45.9	48.4
XM(I/N)10-5	459	777	164	127	48.9	51.9
XM(I/N)10-6	489	807	164	127	49.2	52.5
XM(I/N)10-7	524	864	186	120	56.7	60.6
XM(I/N)10-8	554	894	186	120	57.2	62.1
XM(I/N)10-9	584	924	186	120	59.7	63.2
XM(I/N)10-10	614	954	186	120	61.9	66.4
XM(I/N)10-12	674	1014	186	120	64.7	73.0
XM(I/N)10-14	766	1163	210	142	75.1	77.1
XM(I/N)10-16	826	1223	210	142	77.8	80.3
XM(I/N)10-18	886	1283	210	142	84.6	86.9
XM(I/N)10-20	946	1343	210	142	86.9	87.7
XM(I/N)10-22	1006	1403	210	142	89.6	95.6

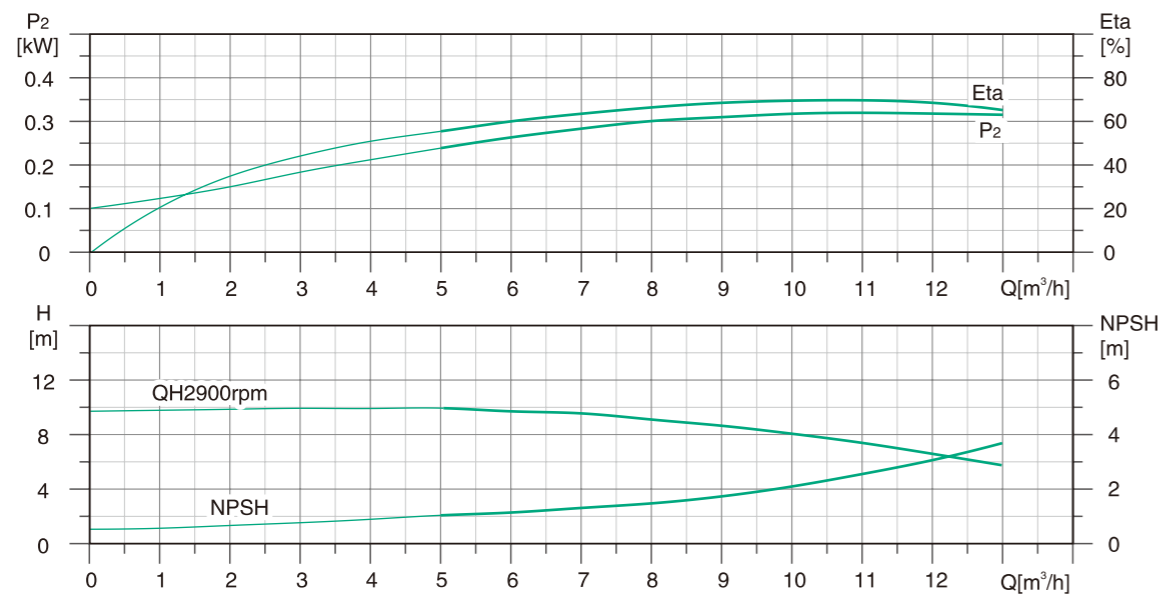

Model	Power (kW)	Q (m³/h)	5	6	8	10	12	13
XM(I/N)10-2	0.75	H (m)	20	19	18	15	12	10
XM(I/N)10-3	1.1		30	29	26	23	18	16
XM(I/N)10-4	1.5		40	40	36	32	26	23
XM(I/N)10-5	2.2		51	50	46	40	33	29
XM(I/N)10-6	2.2		61	59	55	48	39	35
XM(I/N)10-7	3		72	70	65	56	46	41
XM(I/N)10-8	3		82	80	74	64	53	46
XM(I/N)10-9	3		92	89	82	70	59	52
XM(I/N)10-10	4		102	100	93	80	66	59
XM(I/N)10-12	4		122	119	110	95	79	69
XM(I/N)10-14	5.5		143	140	130	113	94	82
XM(I/N)10-16	5.5		163	159	148	128	106	93
XM(I/N)10-18	7.5		185	182	169	147	123	109
XM(I/N)10-20	7.5		206	201	188	164	136	119
XM(I/N)10-22	7.5		226	221	206	178	147	130

### Performance Curves

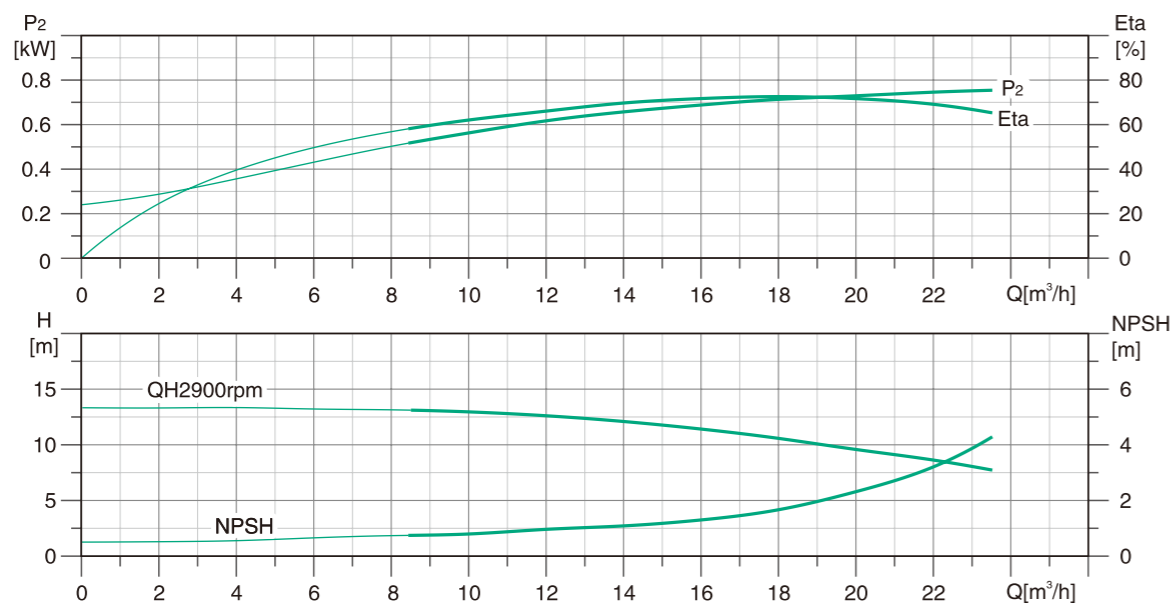
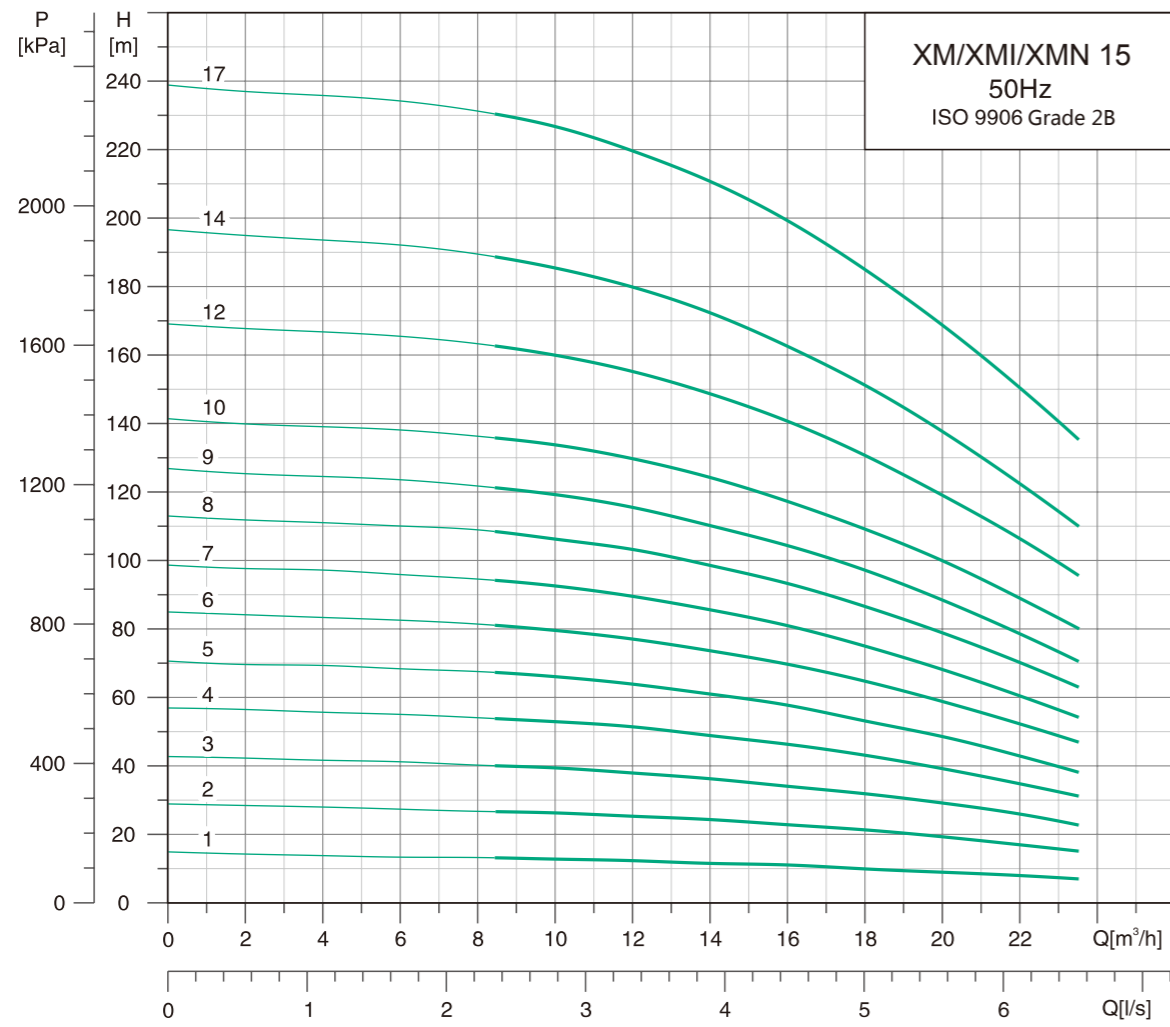

### Dimension Drawing

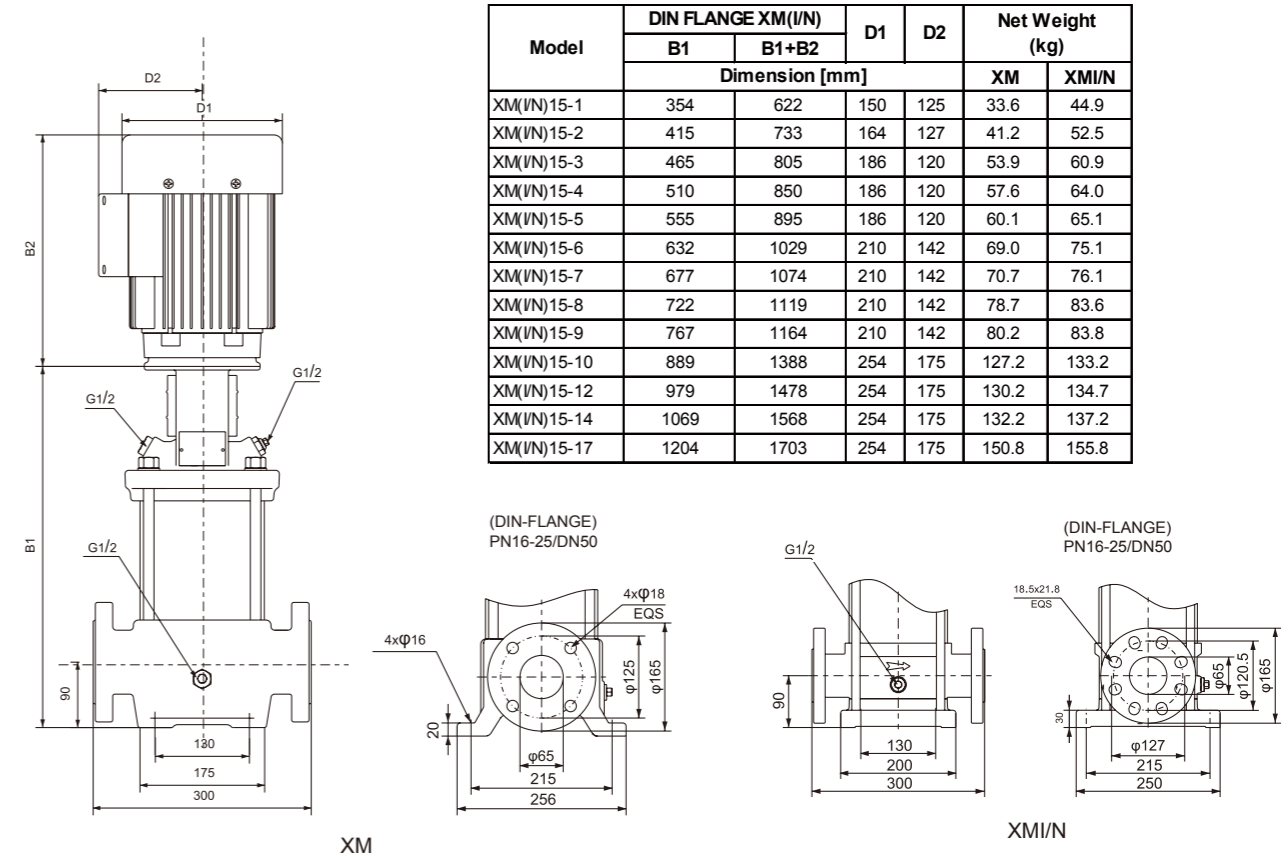

Model	DIN FLANGE XM(I/N)		D1	D2	Net Weight (kg)	
	B1	B1+B2			XM	XMI/N
	Dimension [mm]					
XM(I/N)15-1	354	622	150	125	33.6	44.9
XM(I/N)15-2	415	733	164	127	41.2	52.5
XM(I/N)15-3	465	805	186	120	53.9	60.9
XM(I/N)15-4	510	850	186	120	57.6	64.0
XM(I/N)15-5	555	895	186	120	60.1	65.1
XM(I/N)15-6	632	1029	210	142	69.0	75.1
XM(I/N)15-7	677	1074	210	142	70.7	76.1
XM(I/N)15-8	722	1119	210	142	78.7	83.6
XM(I/N)15-9	767	1164	210	142	80.2	83.8
XM(I/N)15-10	889	1388	254	175	127.2	133.2
XM(I/N)15-12	979	1478	254	175	130.2	134.7
XM(I/N)15-14	1069	1568	254	175	132.2	137.2
XM(I/N)15-17	1204	1703	254	175	150.8	155.8

Model	Power (kW)	Q (m³/h)	H (m)						
			8.5	12	15	18	21	23.5	
XM(I/N)15-1	1.1		13	12	11	10	9	7	
XM(I/N)15-2	2.2		26	25	23	21	18	15	
XM(I/N)15-3	3		40	38	35	32	28	22	
XM(I/N)15-4	4		55	51	47	43	38	32	
XM(I/N)15-5	4		68	64	58	53	48	38	
XM(I/N)15-6	5.5		81	77	71	64	58	47	
XM(I/N)15-7	5.5		95	89	83	75	65	52	
XM(I/N)15-8	7.5		108	103	96	86	75	62	
XM(I/N)15-9	7.5		121	115	108	97	84	70	
XM(I/N)15-10	11		136	129	120	109	95	80	
XM(I/N)15-12	11		164	155	142	130	114	95	
XM(I/N)15-14	11		189	180	166	151	130	110	
XM(I/N)15-17	15		231	219	205	185	160	135	

### Performance Curves

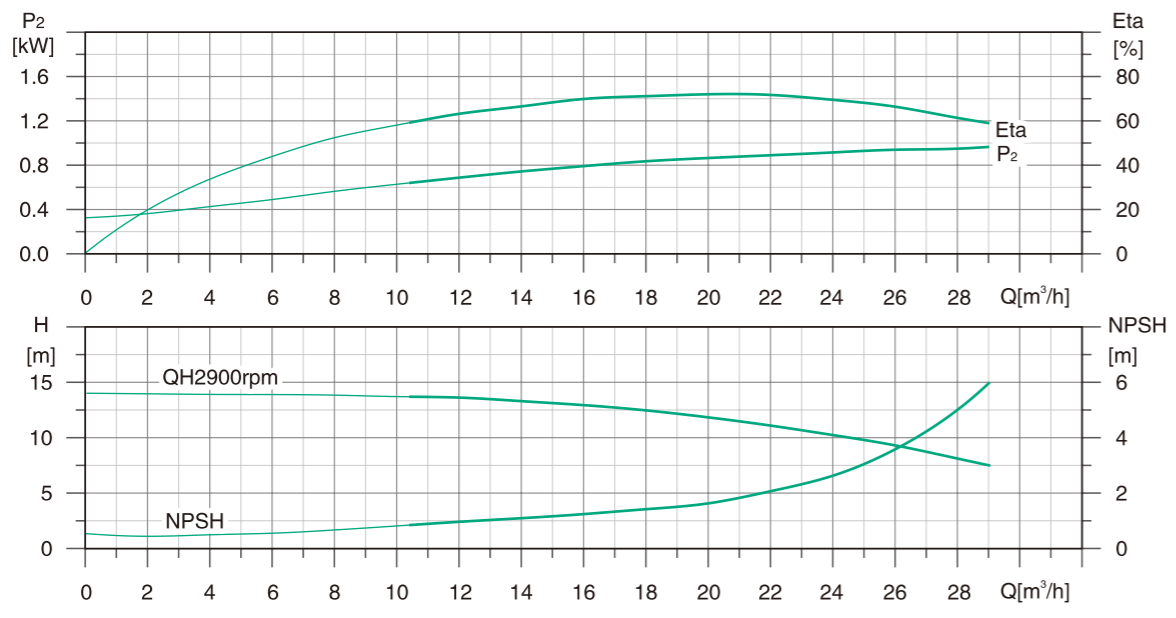
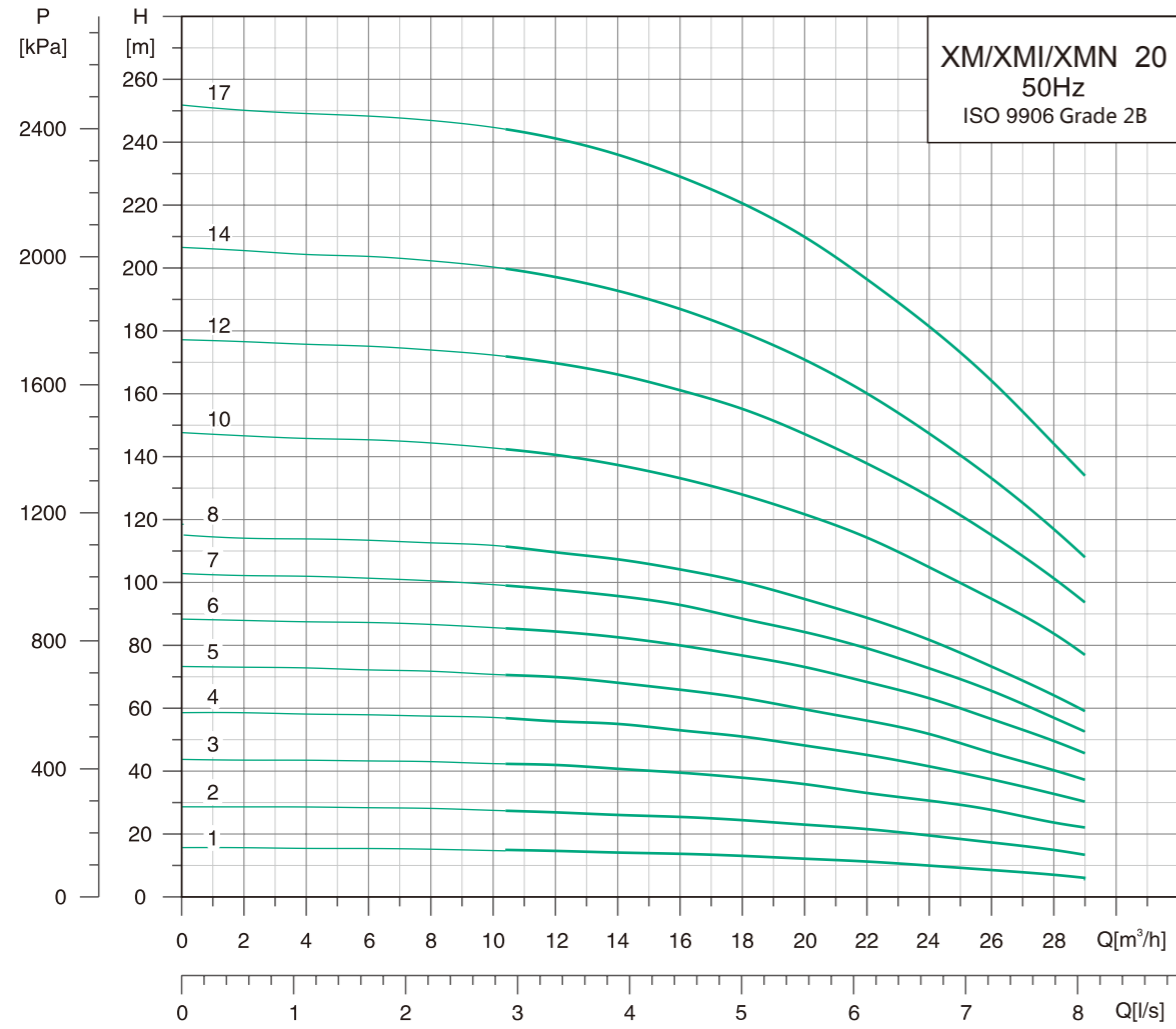

### Dimension Drawing

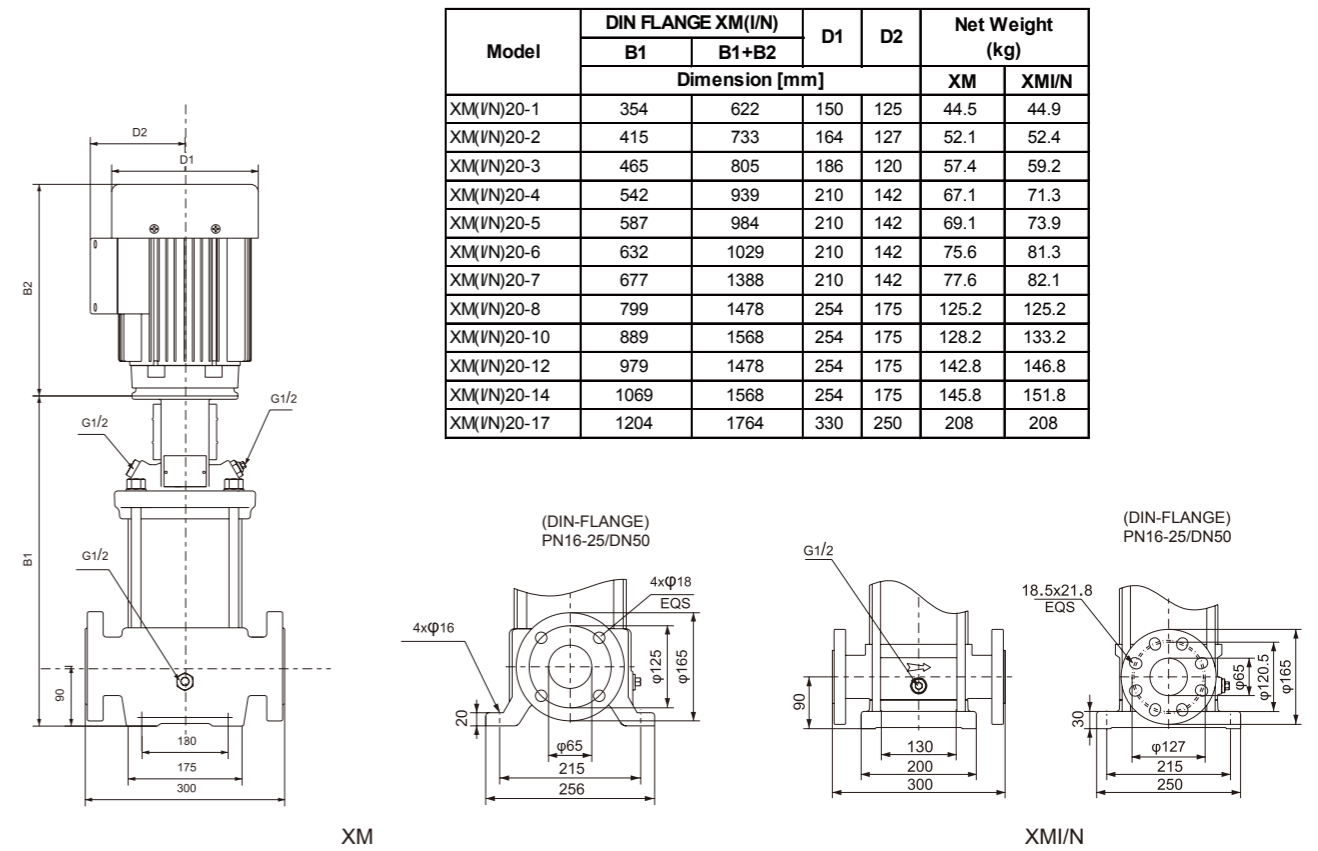

Model	DIN FLANGE XM(I/N)		D1	D2	Net Weight (kg)	
	B1	B1+B2			XM	XMI/N
	Dimension [mm]					
XM(VN)20-1	354	622	150	125	44.5	44.9
XM(VN)20-2	415	733	164	127	52.1	52.4
XM(VN)20-3	465	805	186	120	57.4	59.2
XM(VN)20-4	542	939	210	142	67.1	71.3
XM(VN)20-5	587	984	210	142	69.1	73.9
XM(VN)20-6	632	1029	210	142	75.6	81.3
XM(VN)20-7	677	1388	210	142	77.6	82.1
XM(VN)20-8	799	1478	254	175	125.2	125.2
XM(VN)20-10	889	1568	254	175	128.2	133.2
XM(VN)20-12	979	1478	254	175	142.8	146.8
XM(VN)20-14	1069	1568	254	175	145.8	151.8
XM(VN)20-17	1204	1764	330	250	208	208

Model	Power (kW)	Q (m³/h)	H (m)							
			10.5	12	16	20	24	28	28.5	
XM(VN)20-1	1.1		13	13	12	10.5	9	6.5	6	
XM(VN)20-2	2.2		28	27	25	22.5	19	15	13	
XM(VN)20-3	4		42	42	39	36	30	23	22	
XM(VN)20-4	5.5		58	56	53	48	41	32	30	
XM(VN)20-5	5.5		71	70	66	60	52	40	38	
XM(VN)20-6	7.5		86	84	80	72	62	49	45	
XM(VN)20-7	7.5		99	97	93	84	72	57	52	
XM(VN)20-8	11		115	113	107	96	85	67	63	
XM(VN)20-10	11		142	140	132	120	105	83	78	
XM(VN)20-12	15		172	169	161	144	127	101	94	
XM(VN)20-14	15		200	197	187	168	147	117	109	
XM(VN)20-17	18.5		245	241	229	205	181	144	135	

### Performance Curves

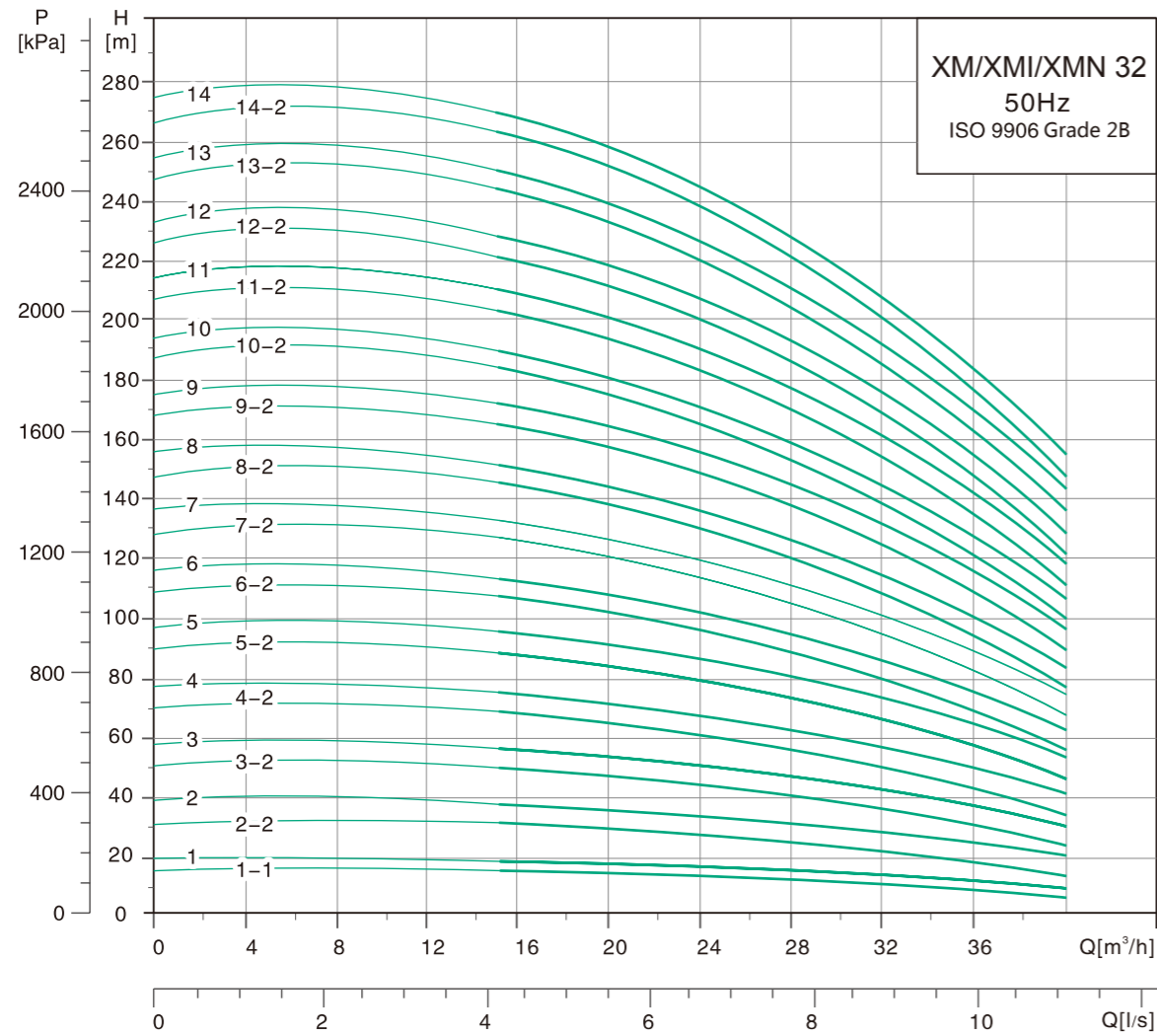

### Dimension Drawing

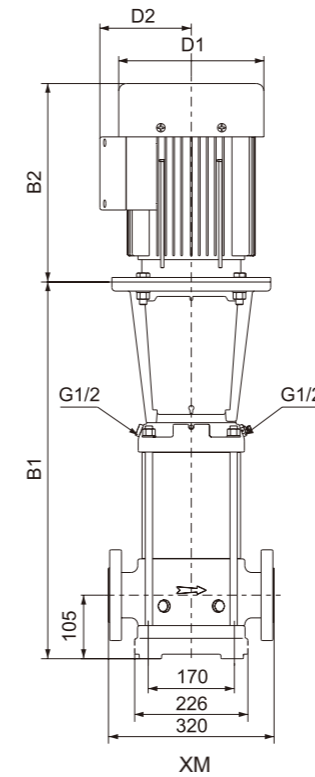

Model	DIN FLANGE XM(I/N)		D1	D2	Net Weight (kg)	
	B1	B1+B2			XM	XMI/N
	Dimension [mm]					
XM(I/N)32-1-1	455	773	164	127	60.2	61.6
XM(I/N)32-1	455	773	164	127	62.2	63.6
XM(I/N)32-2-2	525	865	186	120	70.5	72.6
XM(I/N)32-2	525	865	186	120	72.7	74.8
XM(I/N)32-3-2	645	1042	210	142	100.8	100.5
XM(I/N)32-3	645	1042	210	142	98.9	100.5
XM(I/N)32-4-2	715	1112	210	142	107.1	108.6
XM(I/N)32-4	715	1112	210	142	107.1	108.6
XM(I/N)32-5-2	895	1394	254	175	128.2	149.2
XM(I/N)32-5	895	1394	254	175	128.2	149.2
XM(I/N)32-6-2	965	1464	254	175	132.2	152.1
XM(I/N)32-6	965	1464	254	175	132.2	152.1
XM(I/N)32-7-2	1035	1534	254	175	165.3	167.5
XM(I/N)32-7	1035	1534	254	175	165.3	167.5
XM(I/N)32-8-2	1105	1604	254	175	167.7	170.5
XM(I/N)32-8	1105	1604	254	175	167.7	170.5
XM(I/N)32-9-2	1175	1735	330	250	219.1	221.6
XM(I/N)32-9	1175	1735	334	250	219.1	221.6
XM(I/N)32-10-2	1245	1805	334	250	221.3	224.5
XM(I/N)32-10	1245	1805	334	250	221.3	224.5
XM(I/N)32-11-2	1315	1915	380	280	260.6	263.3
XM(I/N)32-11	1315	1915	380	280	260.6	263.3
XM(I/N)32-12-2	1385	1985	380	280	262.8	266.2
XM(I/N)32-12	1385	1985	380	280	262.8	266.2
XM(I/N)32-13-2	1455	2135	420	305	322.6	323.6
XM(I/N)32-13	1455	2135	420	305	322.6	323.6
XM(I/N)32-14-2	1525	2205	420	305	324.8	326.5
XM(I/N)32-14	1525	2205	420	305	324.8	326.5

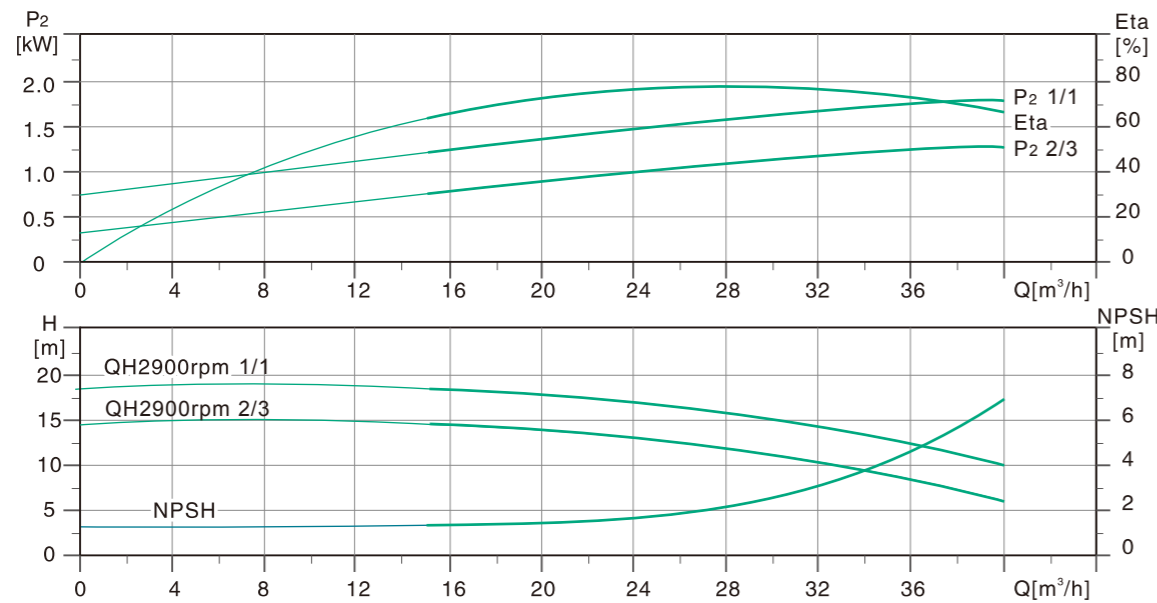
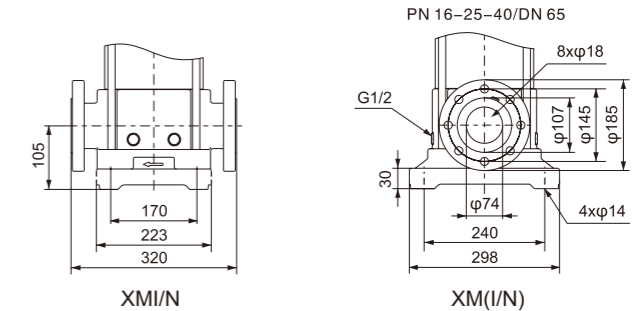

Model	Power (kW)	Q (m³/h)	H (m)						
			15	20	25	32	35	40	
XM(I/N)32-1-1	1.5	15	14	13	10	8	5		
XM(I/N)32-1	2.2	18	17	16	13	11.5	9		
XM(I/N)32-2-2	3	31	29.5	26.5	20.5	17.5	12		
XM(I/N)32-2	4	37	35.5	32.5	27.5	25	19.5		
XM(I/N)32-3-2	5.5	50	47	49	35.5	31	22.5		
XM(I/N)32-3	5.5	55.5	53	60	41.5	37.5	29.5		
XM(I/N)32-4-2	7.5	68.5	65	66	49.5	44	32.5		
XM(I/N)32-4	7.5	74.5	70.5	78	56	50.5	40		
XM(I/N)32-5-2	11	88.5	84.5	84	65.5	59.0	45		
XM(I/N)32-5	11	94.5	93	84.0	72	65	52		
XM(I/N)32-6-2	11	107	102	95	79.5	71	55		
XM(I/N)32-6	11	113	108	100	85.5	77.5	61.5		
XM(I/N)32-7-2	15	127	121	112	94.5	85	66.5		
XM(I/N)32-7	15	133	126	118	101	92	73.5		
XM(I/N)32-8-2	15	145	138	128	108	98	76.5		
XM(I/N)32-8	15	151	144	134	115	104	83		
XM(I/N)32-9-2	18.5	165	158	147	124	112	88.5		
XM(I/N)32-9	18.5	171	163	152	131	119	95.5		
XM(I/N)32-10-2	18.5	184	175	163	138	125	98.5		
XM(I/N)32-10	18.5	190	181	169	145	133	106		
XM(I/N)32-11-2	22	203	194	181	154	140	111		
XM(I/N)32-11	22	209	200	187	161	147	118		
XM(I/N)32-12-2	22	222	212	197	168	152	121		
XM(I/N)32-12	22	227	217	203	176	160	128		
XM(I/N)32-13-2	30	244	233	218	187	169	136		
XM(I/N)32-13	30	250	239	224	193	177	145		
XM(I/N)32-14-2	30	263	251	234	201	183	146		
XM(I/N)32-14	30	269	258	241	207	188	156		

### Performance Curves

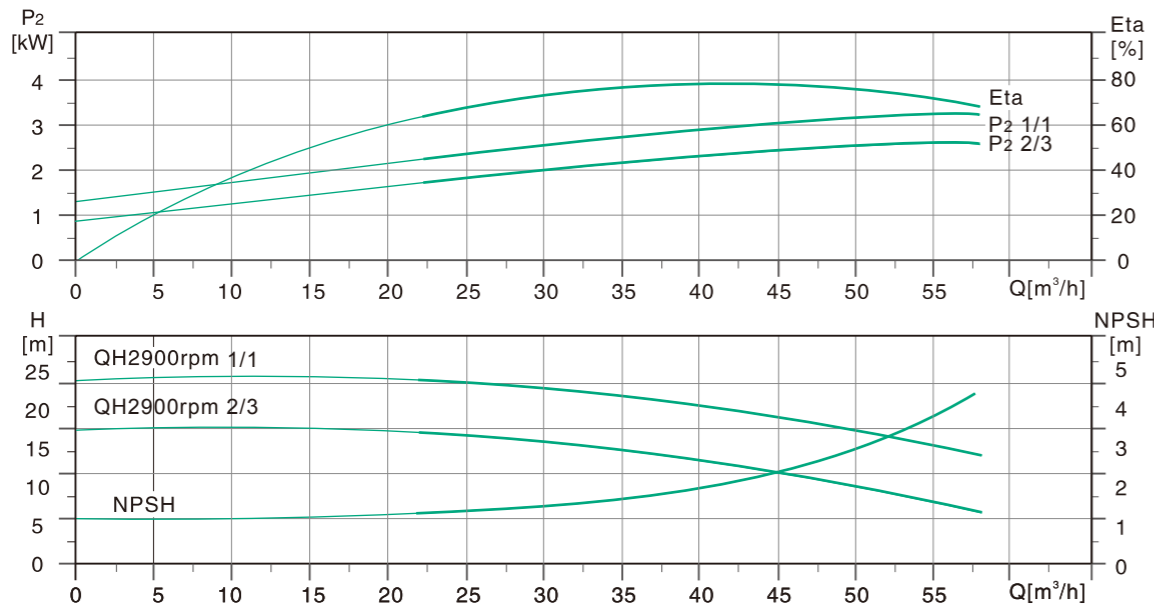
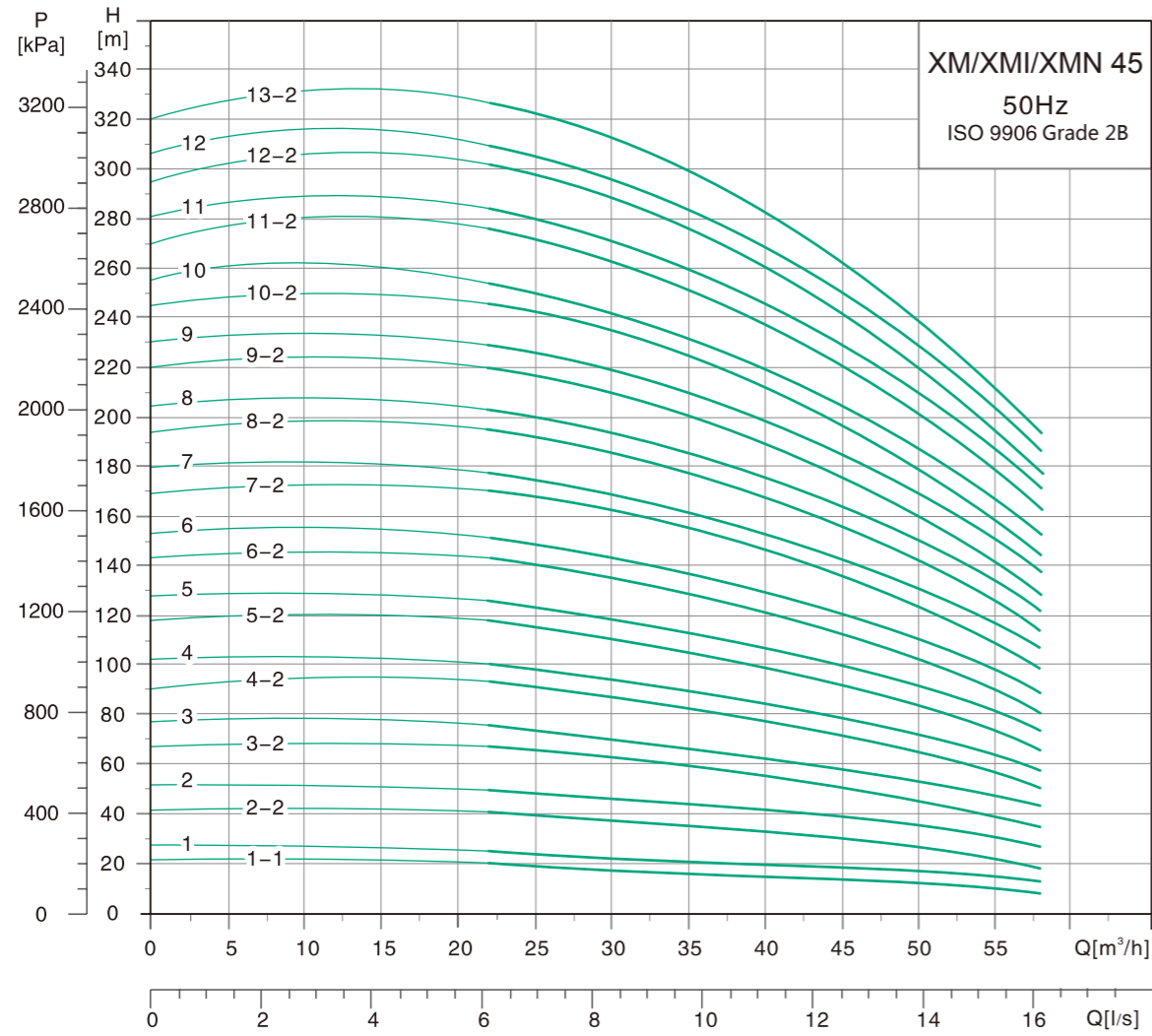

### Dimension Drawing

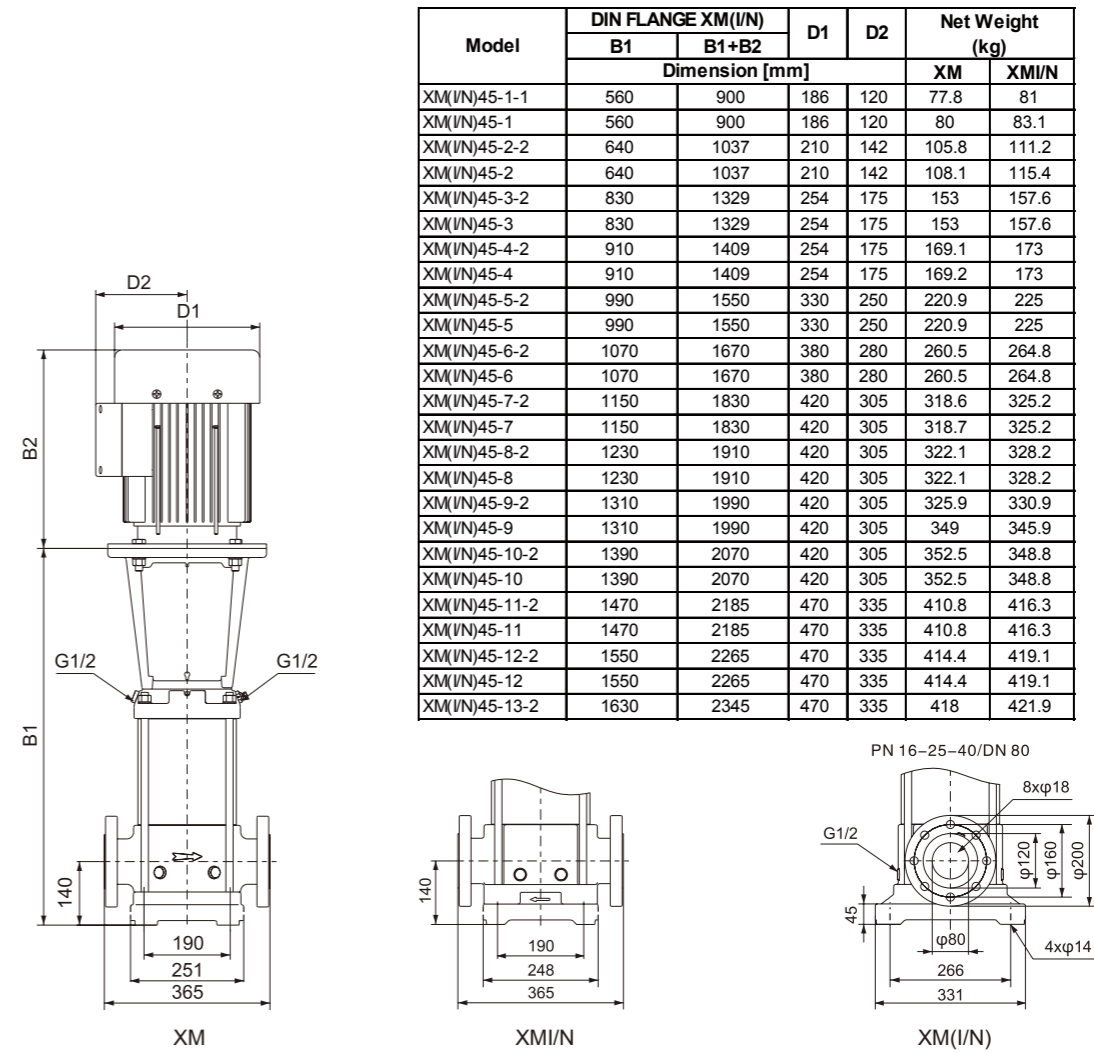

Model	DIN FLANGE XM(I/N)		D1	D2	Net Weight (kg)	
	B1	B1+B2			XM	XMI/N
	Dimension [mm]					
XM(VN)45-1-1	560	900	186	120	77.8	81
XM(VN)45-1	560	900	186	120	80	83.1
XM(VN)45-2-2	640	1037	210	142	105.8	111.2
XM(VN)45-2	640	1037	210	142	108.1	115.4
XM(VN)45-3-2	830	1329	254	175	153	157.6
XM(VN)45-3	830	1329	254	175	153	157.6
XM(VN)45-4-2	910	1409	254	175	169.1	173
XM(VN)45-4	910	1409	254	175	169.2	173
XM(VN)45-5-2	990	1550	330	250	220.9	225
XM(VN)45-5	990	1550	330	250	220.9	225
XM(VN)45-6-2	1070	1670	380	280	260.5	264.8
XM(VN)45-6	1070	1670	380	280	260.5	264.8
XM(VN)45-7-2	1150	1830	420	305	318.6	325.2
XM(VN)45-7	1150	1830	420	305	318.7	325.2
XM(VN)45-8-2	1230	1910	420	305	322.1	328.2
XM(VN)45-8	1230	1910	420	305	322.1	328.2
XM(VN)45-9-2	1310	1990	420	305	325.9	330.9
XM(VN)45-9	1310	1990	420	305	349	345.9
XM(VN)45-10-2	1390	2070	420	305	352.5	348.8
XM(VN)45-10	1390	2070	420	305	352.5	348.8
XM(VN)45-11-2	1470	2185	470	335	410.8	416.3
XM(VN)45-11	1470	2185	470	335	410.8	416.3
XM(VN)45-12-2	1550	2265	470	335	414.4	419.1
XM(VN)45-12	1550	2265	470	335	414.4	419.1
XM(VN)45-13-2	1630	2345	470	335	418	421.9

Model	Power (kW)	Q (m <sup>3</sup> /h)	H (m)							
			25	30	35	40	45	50	55	58
XM(VN)45-1-1	3	20	19.5	18	17	15	12.5	10.5	8	
XM(VN)45-1	4	24	23	22	20.5	19	17.5	15	13	
XM(VN)45-2-2	5.5	31	39	37	34	30.5	26.5	22	18	
XM(VN)45-2	7.5	48.5	46.5	44.5	42	39	35	31	28	
XM(VN)45-3-2	11	66	64	61	56.5	52	46	40	35	
XM(VN)45-3	11	73.5	71	68	64	59.5	54	47.5	43	
XM(VN)45-4-2	15	91	88	84	78.5	72	64.5	56	50	
XM(VN)45-4	15	98.5	95	91	85.5	79.5	72.5	64	59	
XM(VN)45-5-2	18.5	116	113	107	101	92.5	83.5	73	66	
XM(VN)45-5	18.5	124	120	115	108	100	91.5	81	74	
XM(VN)45-6-2	22	142	137	131	122	113	103	90	82	
XM(VN)45-6	22	149	144	138	130	121	111	98	90	
XM(VN)45-7-2	30	168	163	156	147	135	123	109	99	
XM(VN)45-7	30	176	171	163	155	144	132	116	108	
XM(VN)45-8-2	30	193	187	179	168	155	142	126	115	
XM(VN)45-8	30	200	194	187	176	164	149	134	122	
XM(VN)45-9-2	30	217	211	202	189	175	159	142	130	
XM(VN)45-9	37	226	219	210	199	185	170	151	140	
XM(VN)45-10-2	37	243	236	225	212	196	179	159	146	
XM(VN)45-10	37	251	243	233	220	205	187	166	154	
XM(VN)45-11-2	45	273	264	253	238	222	201	179	164	
XM(VN)45-11	45	281	272	261	246	230	209	187	172	
XM(VN)45-12-2	45	298	289	276	261	242	220	195	179	
XM(VN)45-12	45	306	296	284	268	251	229	204	188	
XM(VN)45-13-2	45	323	313	300	283	263	239	212	195	

### Performance Curves

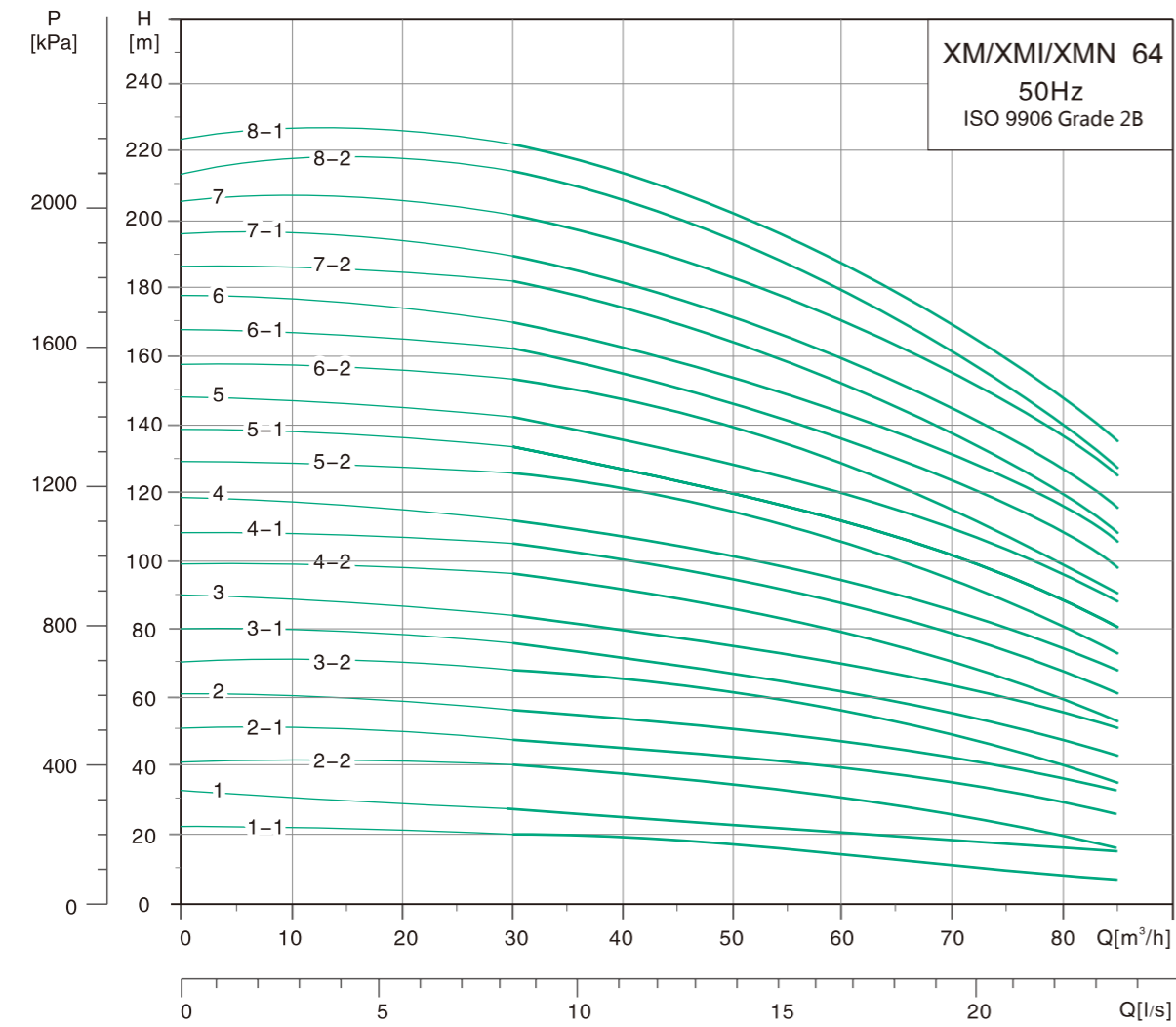

### Dimension Drawing

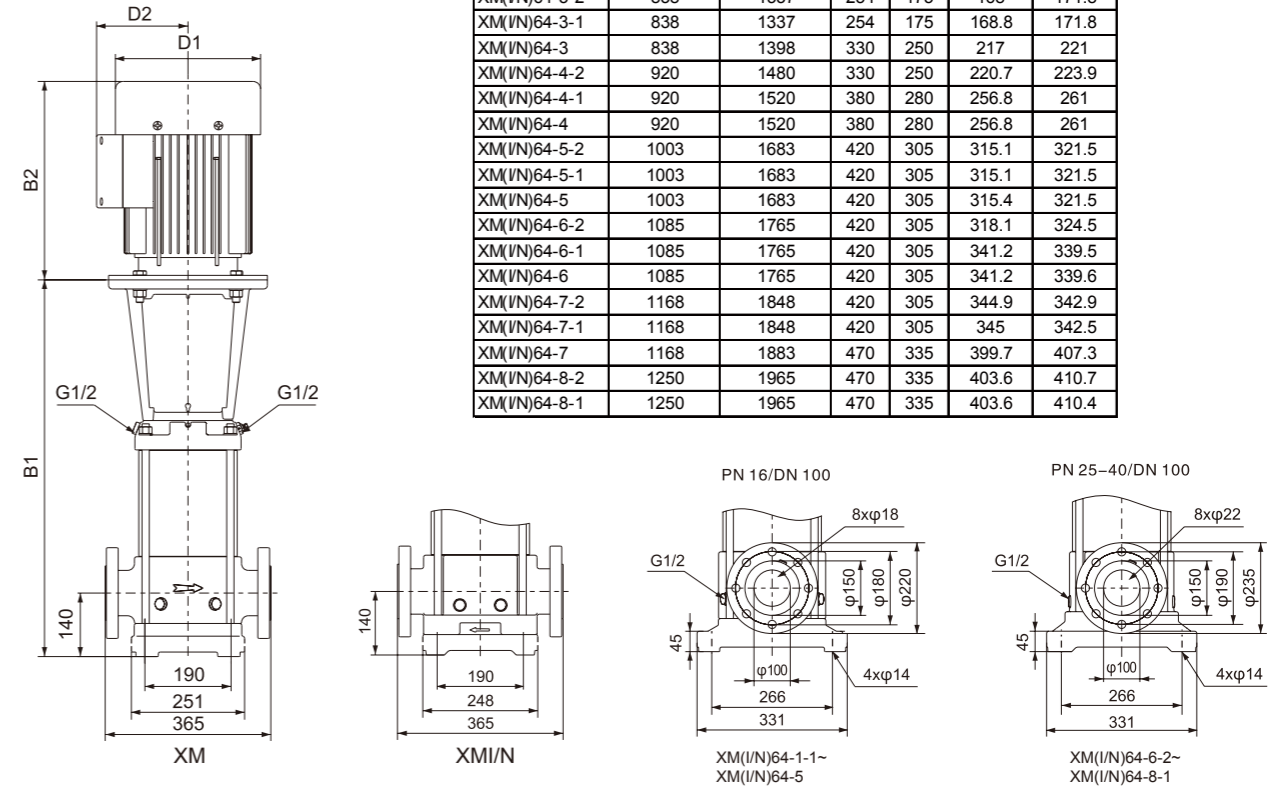

Model	DIN FLANGE XM(I/N)		D1	D2	Net Weight (kg)	
	B1	B1+B2			XM	XMI/N
	Dimension [mm]					
XM(I/N)64-1-1	563	903	186	124	85	84.4
XM(I/N)64-1	563	960	210	142	104.7	110.1
XM(I/N)64-2-2	645	1042	210	142	113.7	117.3
XM(I/N)64-2-1	755	1254	254	175	151.4	156
XM(I/N)64-2	755	1254	254	175	152.2	156
XM(I/N)64-3-2	838	1337	254	175	168	171.8
XM(I/N)64-3-1	838	1337	254	175	168.8	171.8
XM(I/N)64-3	838	1398	330	250	217	221
XM(I/N)64-4-2	920	1480	330	250	220.7	223.9
XM(I/N)64-4-1	920	1520	380	280	256.8	261
XM(I/N)64-4	920	1520	380	280	256.8	261
XM(I/N)64-5-2	1003	1683	420	305	315.1	321.5
XM(I/N)64-5-1	1003	1683	420	305	315.1	321.5
XM(I/N)64-5	1003	1683	420	305	315.4	321.5
XM(I/N)64-6-2	1085	1765	420	305	318.1	324.5
XM(I/N)64-6-1	1085	1765	420	305	341.2	339.5
XM(I/N)64-6	1085	1765	420	305	341.2	339.6
XM(I/N)64-7-2	1168	1848	420	305	344.9	342.9
XM(I/N)64-7-1	1168	1848	420	305	345	342.5
XM(I/N)64-7	1168	1883	470	335	399.7	407.3
XM(I/N)64-8-2	1250	1965	470	335	403.6	410.7
XM(I/N)64-8-1	1250	1965	470	335	403.6	410.4

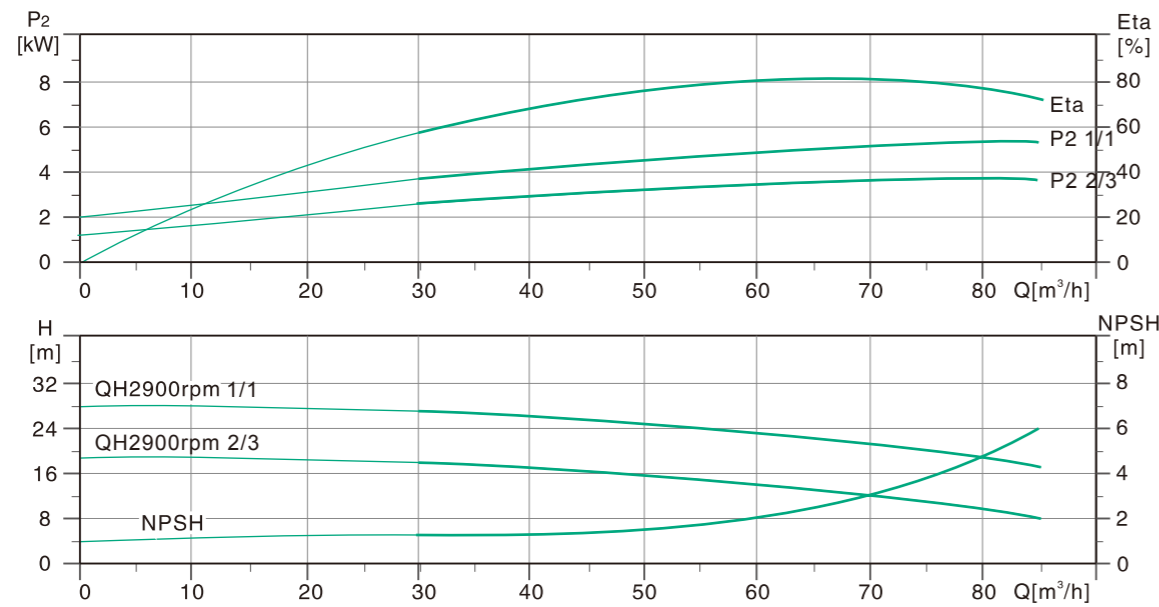

Model	Power (kW)	Q (m³/h)	H (m)							
			30	40	50	64	70	80	85	
XM(I/N)64-1-1	4	20	19	17.5	14	12	8.5	6		
XM(I/N)64-1	5.5	27	25.5	23.5	21	20	17	15		
XM(I/N)64-2-2	7.5	40	38	35.5	29	25.5	19	15		
XM(I/N)64-2-1	11	48	45.5	42.5	37	34.5	29	25		
XM(I/N)64-2	11	55	52.5	49.5	44	41.5	36	33		
XM(I/N)64-3-2	15	68	65.5	60	52.5	48.5	40	35		
XM(I/N)64-3-1	15	75.5	72	67.5	59.5	55.5	47	42		
XM(I/N)64-3	18.5	83.5	80	76	68	64	56	51		
XM(I/N)64-4-2	18.5	96	92.5	87	75.5	70	59	52		
XM(I/N)64-4-1	22	104	100	94.5	83.5	78.5	67.5	61		
XM(I/N)64-4	22	112	107	102	91	85.5	74.5	69		
XM(I/N)64-5-2	30	126	122	115	101	94	80.5	73		
XM(I/N)64-5-1	30	134	129	122	109	102	88	81		
XM(I/N)64-5	30	141	136	129	116	109	96	89		
XM(I/N)64-6-2	30	154	148	140	124	115	99	90		
XM(I/N)64-6-1	37	162	156	148	132	124	108	98		
XM(I/N)64-6	37	170	163	155	139	131	116	107		
XM(I/N)64-7-2	37	182	176	166	147	138	119	109		
XM(I/N)64-7-1	37	190	183	173	155	145	126	110		
XM(I/N)64-7	45	202	194	184	165	155	136	126		
XM(I/N)64-8-2	45	214	207	196	174	163	140	128		
XM(I/N)64-8-1	45	222	214	203	181	170	148	135		

### Performance Curves

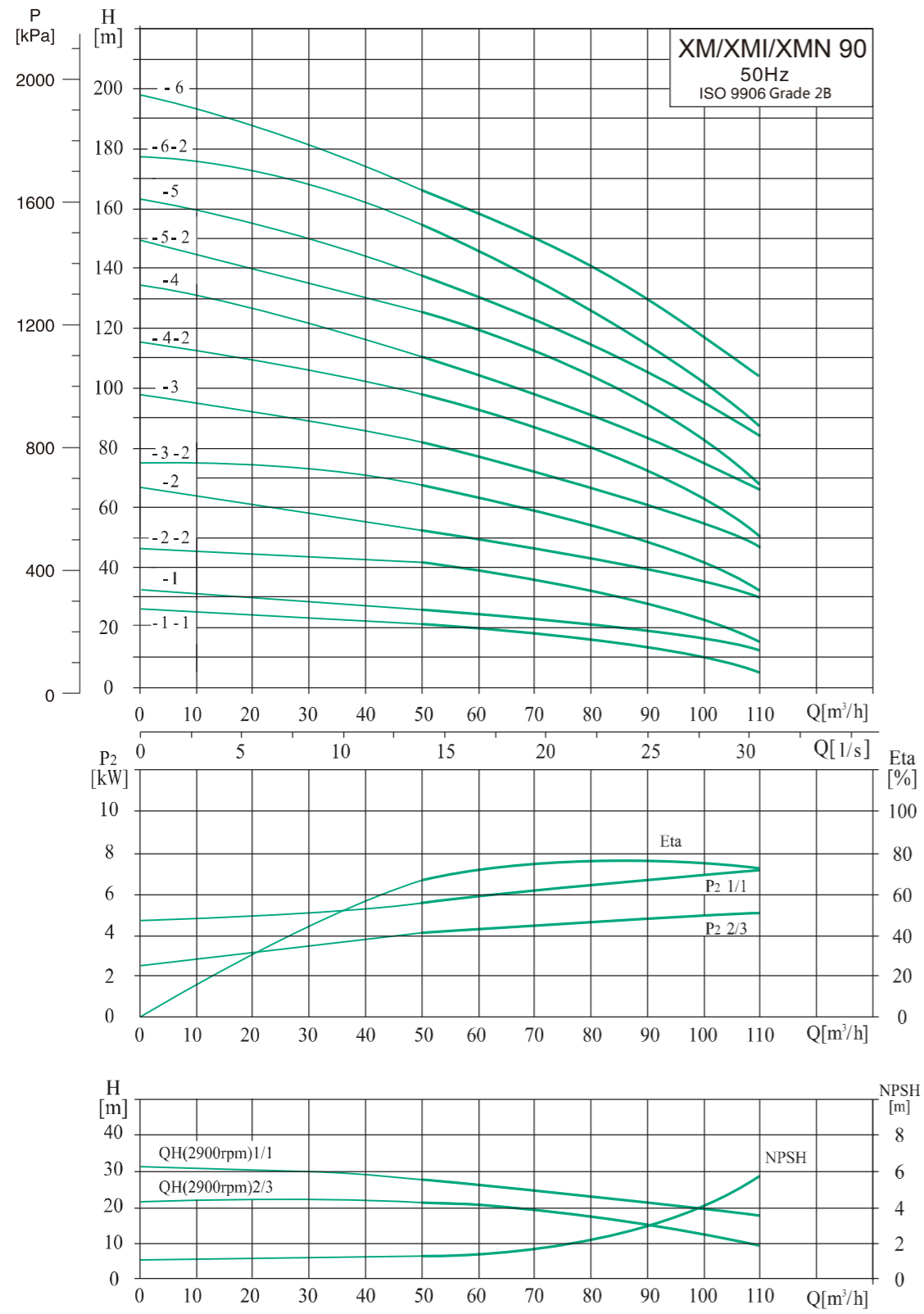

### Dimension Drawing

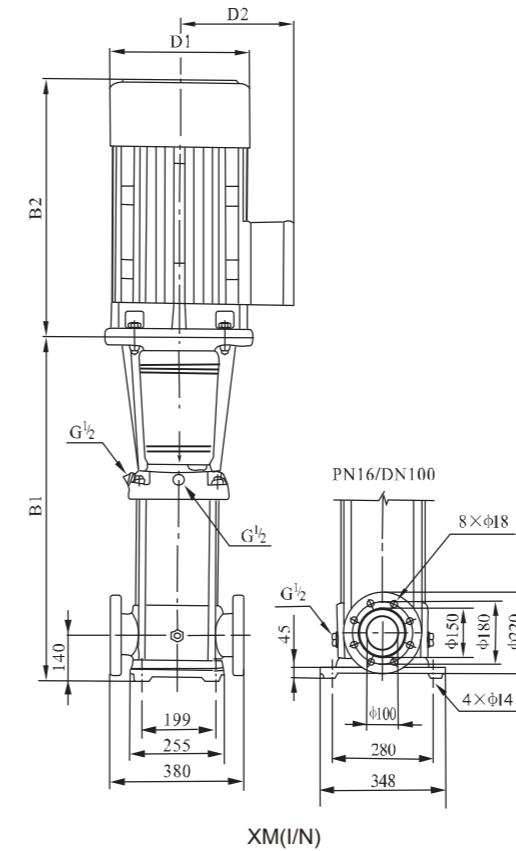

Model	DIN FLANGE XM(I/N)		D1	D2	Net Weight (kg)	
	B1	B1+B2			XM	XMI/N
	Dimension [mm]					
XM(I/N)90-1-1	572.5	969.5	210	142	107.9	115.9
XM(I/N)90-1	572.5	969.5	210	142	113.1	121.1
XM(I/N)90-2-2	774.5	1273.5	254	175	155.2	162.2
XM(I/N)90-2	774.5	1273.5	254	175	167.8	174.8
XM(I/N)90-3-2	866.5	1426.5	330	250	220	228
XM(I/N)90-3	866.5	1466.5	380	280	256	264
XM(I/N)90-4-2	958.5	1638.5	420	305	319	326
XM(I/N)90-4	958.5	1638.5	420	305	319	326
XM(I/N)90-5-2	1051	1731	420	305	346	354
XM(I/N)90-5	1051	1731	420	305	346	354
XM(I/N)90-6-2	1143	1858	470	335	407	415
XM(I/N)90-6	1143	1858	470	335	407	415

Model	Power (kW)	Q (m³/h)	40	50	60	70	80	90	100	110	120
XM(I/N)90-1-1	5.5	H (m)	22	21	20	18	16	14	10.5	6.5	-
XM(I/N)90-1	7.5		38	26	25	23.5	22	20	17.5	14	10
XM(I/N)90-2-2	11		45	43	41	38	34.5	29.5	24	17	8
XM(I/N)90-2	15		58	55	52	49	46	42	37.5	31.5	25
XM(I/N)90-3-2	18.5		74	71.5	68	63.5	58	51	44	35	24
XM(I/N)90-3	22		88	84.5	80	75.5	70.5	64	58.5	50.5	40
XM(I/N)90-4-2	30		106	102	97	91	84.5	75	65.5	54	40
XM(I/N)90-4	30		120	114	109	103	96	87.5	79.5	69.5	57
XM(I/N)90-5-2	37		136	131	125	118	109	97	86.5	72	55
XM(I/N)90-5	37		150	144	136	129	121	109.5	101	87	72
XM(I/N)90-6-2	45		166	161	154	145	135	121	108	91.5	72
XM(I/N)90-6	45		182	175	166	156	146	133	123	108	90

### Performance Curves

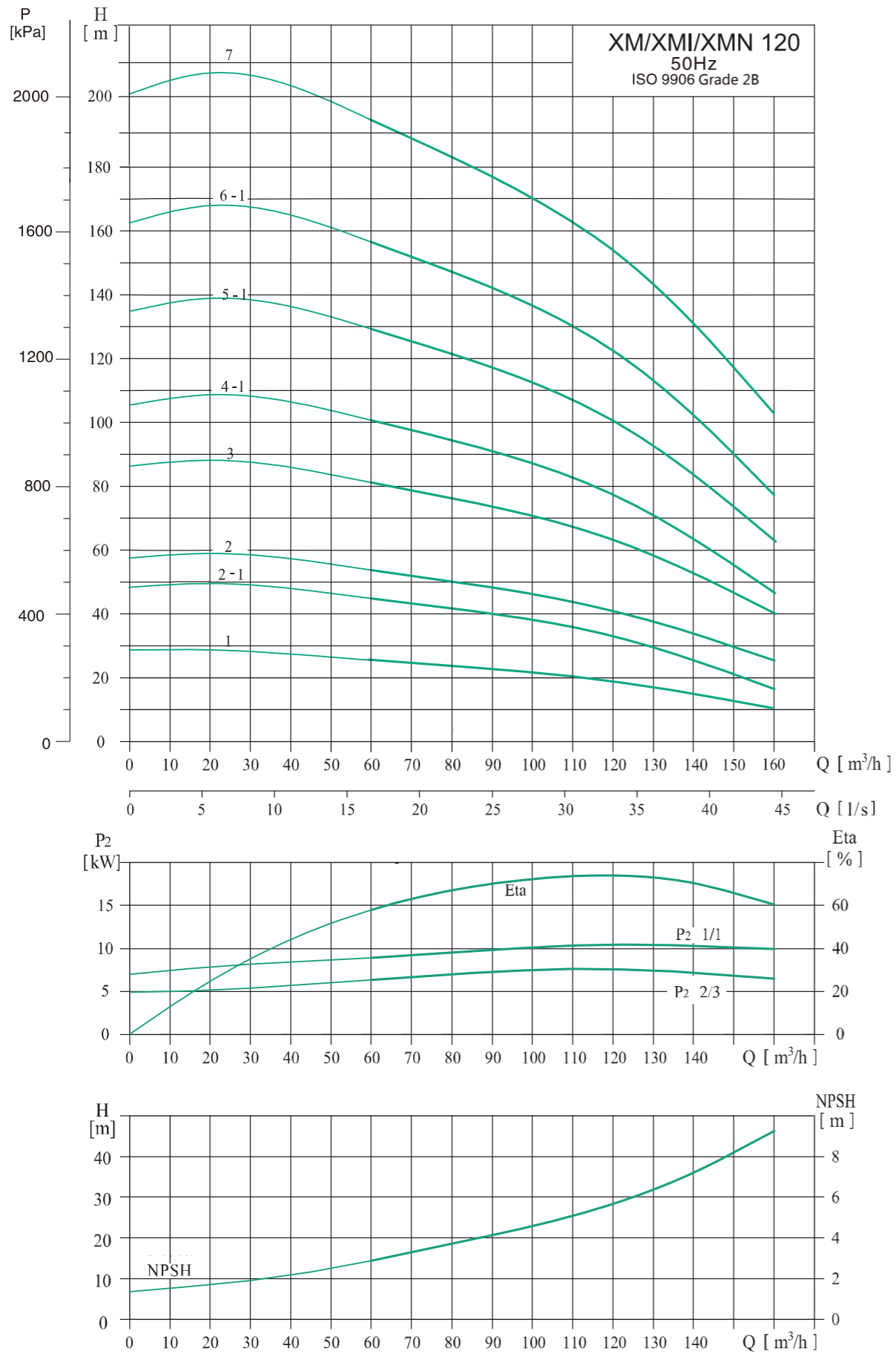

### Dimension Drawing

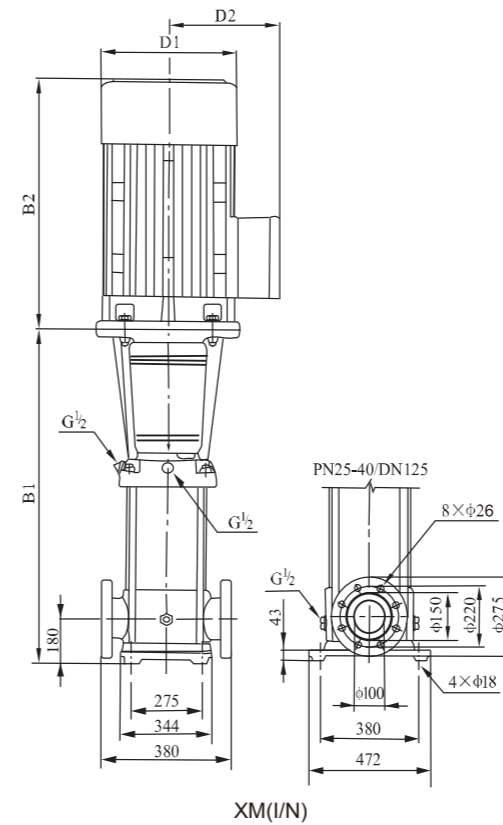

Model	DIN FLANGE XM(I/N)		D1	D2	Net Weight (kg)
	B1	B1+B2			
XM(I/N)120-1	834	1339	318	245	200
XM(I/N)120-2-1	990	1540	318	245	210
XM(I/N)120-2	990	1570	358	265	288
XM(I/N)120-3	1145	1805	420	295	362
XM(I/N)120-4-1	1301	1961	420	295	375
XM(I/N)120-5-1	1460	2150	470	325	443
XM(I/N)120-6-1	1642	2412	510	355	569
XM(I/N)120-7	1797	2642	580	410	741

Model	Power (kW)	Q (m³/h)	H (m)											
			60	70	80	90	100	110	120	130	140	150	160	
XM(I/N)120-1	11	26	24.5	23.5	22	21.5	20	19	27.5	15	13	10		
XM(I/N)120-2-1	18.5	45	43	41.5	40	38.5	36	33	30	26	21.5	17		
XM(I/N)120-2	22	54	52	50	48	46.5	44	41	37.5	33.5	19	26		
XM(I/N)120-3	30	81	78	76	73	70	67	62.5	58	52	46	40		
XM(I/N)120-4-1	37	101	97.5	94	91.5	87.5	83	77.5	71	63	55	46.5		
XM(I/N)120-5-1	45	129	125	121	117	113	107	100	92.5	82.5	73	62.5		
XM(I/N)120-6-1	55	157	152	147.5	143	136.5	130	122	113	102	90	78		
XM(I/N)120-7	75	193	187.5	182	175	168.5	161	152	142	129	116	102		

### Performance Curves

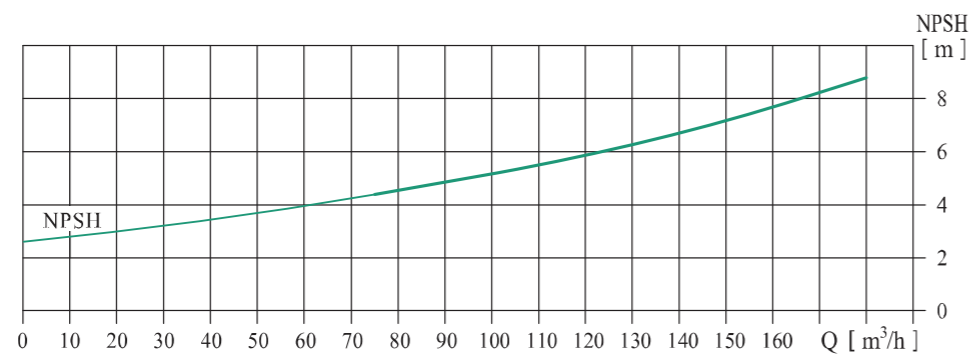
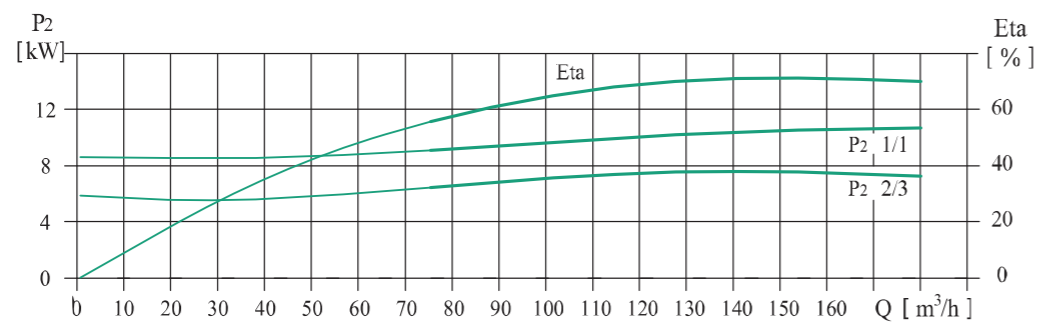
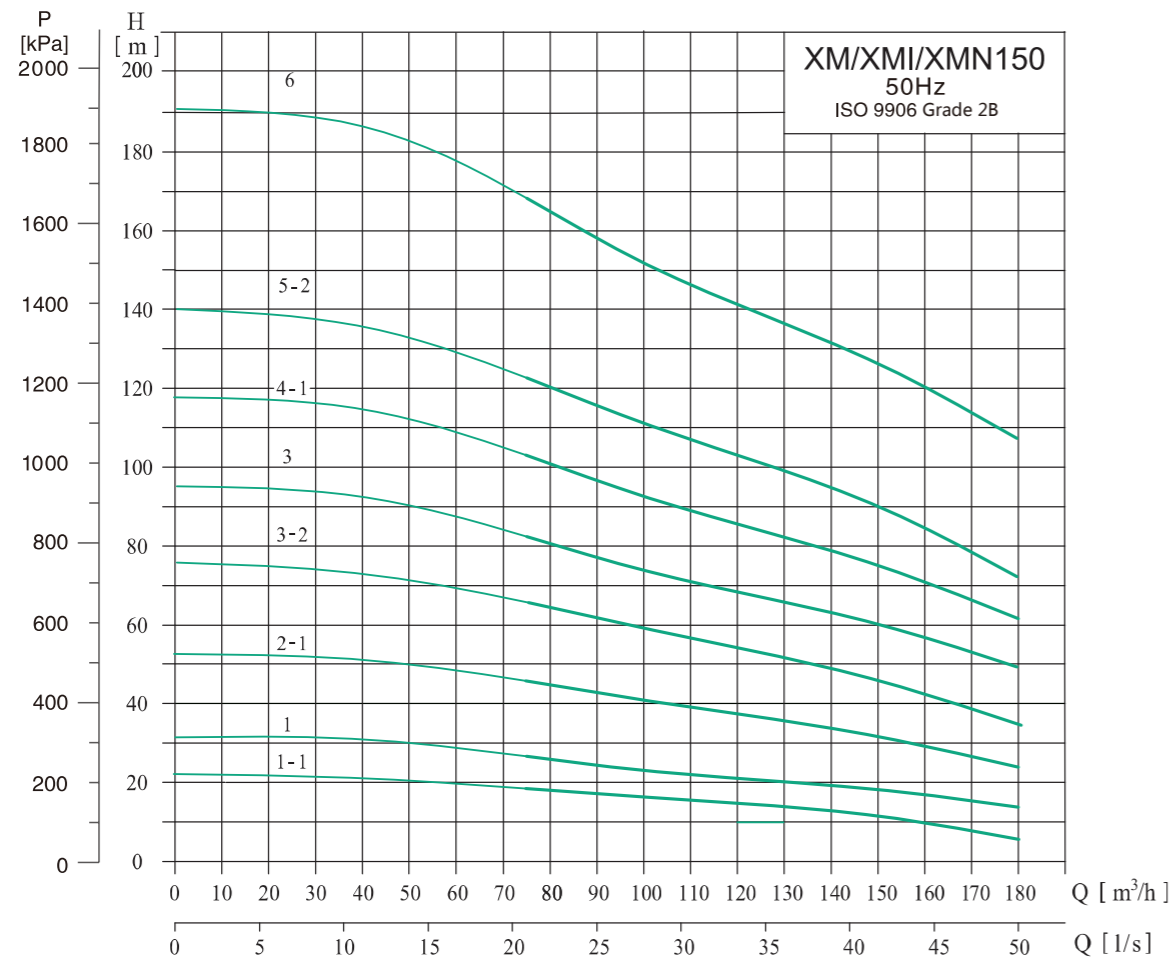

### Dimension Drawing

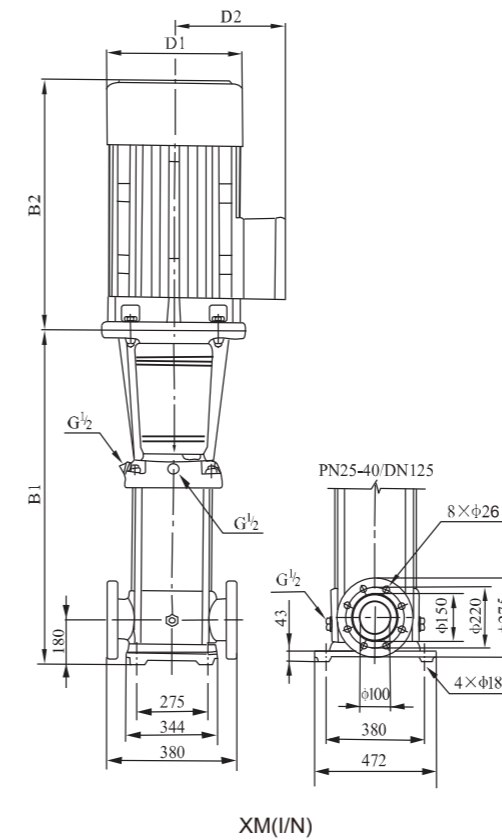

Model	DIN FLANGE XM(I/N)		D1	D2	Net Weight (kg)
	B1	B1+B2			
XM(I/N)150-1-1	834	1339	318	245	200
XM(I/N)150-1	834	1344	318	245	210
XM(I/N)150-2-1	990	1570	358	265	288
XM(I/N)150-3-2	1145	1805	420	295	362
XM(I/N)150-3	1145	1805	420	295	375
XM(I/N)150-4-1	1305	1995	470	325	443
XM(I/N)150-5-2	1486	2256	510	355	569
XM(I/N)150-6	1642	2487	580	410	741

Model	Power (kW)	Q (m³/h)	H (m)												
			80	90	100	110	120	130	140	150	160	170	180		
XM(I/N)150-1-1	11	18	17.5	16.5	15	14	13.5	13	11	9.5	7.5	5			
XM(I/N)150-1	15	25	24	22	21	20	19.5	19	17.5	17	15	13			
XM(I/N)150-2-1	22	45	43	41	39	37.5	36	34	31	29	26	23.5			
XM(I/N)150-3-2	30	64	62	59	56.5	53	51.5	49	46	42	38	35			
XM(I/N)150-3	37	80	77	74	71	68.5	66	63	60	57	53.5	39.5			
XM(I/N)150-4-1	45	101	97	92.5	89	80	82	78.5	75	71	66	61			
XM(I/N)150-5-2	55	120	116	111	107	103	99	94	90	84	78	71.5			
XM(I/N)150-6	75	165	158	151.5	146	141	136	131	126	120	113	107.5			

